



# ALEXANDRE TURPAULT

FRANCE 1847



LIT | BEDLINEN

2022 | Printemps | Été  
Spring | Summer



**ALEXANDRE  
TURPAULT**  
FRANCE 1847

Lit satin et jacquard de coton bio organic cotton sateen and jacquard bedlinens	Teophile	6	Lit metis Halfinen bedlinen	Cachou	46
	Marceau	10		Ontario	46
	Orsay	12		Paris	47
	<b>À la belle étoile</b> <sup>NEW</sup>	<b>14</b>		Venise	48
	Blossom	15			
	Chandernagor	16			
	<b>Envolée</b> <sup>NEW</sup>	<b>17</b>			
	Halatte	18	Accessoires Accessories	Bel Oiseau	52
	Octobre	19		Bloom	53
				Estampe	54
				<b>L'île aux oiseaux</b> <sup>NEW</sup>	<b>55</b>
				Loulou	56
				Nomade	57
				Merveille	58
				<b>Poesie</b> <sup>NEW</sup>	<b>60</b>
				Tsarine	62
				Ashlyn	63
			Velin	63	
			Voltaire	64	
Lit satin et jacquard de coton Cotton sateen, cotton jacquard bedlinens	Canopée	22	Linge de toilette Bathlinen	Essentiel	68
	Quintessence	23		Ess-cadre	69
	Namaste	24-25		Ess-cale	70
		Ess-kimo		70	
				<b>Belize</b> <sup>NEW</sup>	<b>72</b>
			<b>Succulente</b> <sup>NEW</sup>	<b>73</b>	
Lit percale de coton Cotton percale bedlinen	<b>Baroque</b> <sup>NEW</sup>	<b>28</b>	Table Lin linen	<b>Florence</b> <sup>NEW</sup>	<b>76</b>
	Candide	29		Barbade	80
	Sous-bois	30		Domaniale	81
	Trésor	31		<b>Chambray</b> <sup>NEW</sup>	<b>82</b>
		<b>Infusion</b> <sup>NEW</sup>		<b>84</b>	
		Océanide		86	
Lit lin Pure linen bedlinen	Cythère	34	Conseils d'entretien Care instructions		
	Maine	35			
	<b>Nouvelle Vague</b> <sup>NEW</sup>	<b>36-39</b>			
	Bastide	40			
	Keops	41			
	Régence	42			

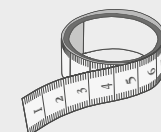

Service sur mesure : dimensions spéciales sur tarif ou sur simple demande.

Custom size service : quotation available on price list or upon request.

Conseils d'entretien  
Care instructions

96

Suivez l'actualité Alexandre Turpault sur  
Facebook, Instagram et Pinterest

Follow Alexandre Turpault on  
Facebook, Instagram and Pinterest





1697

Création du label de qualité des toiles de lin de Cholet par Louis XIV sur l'instigation du grand ministre Colbert.

Creation of the linens of Cholet quality seal by Louis XIV under the instigation of the great French minister Jean-Baptiste Colbert.

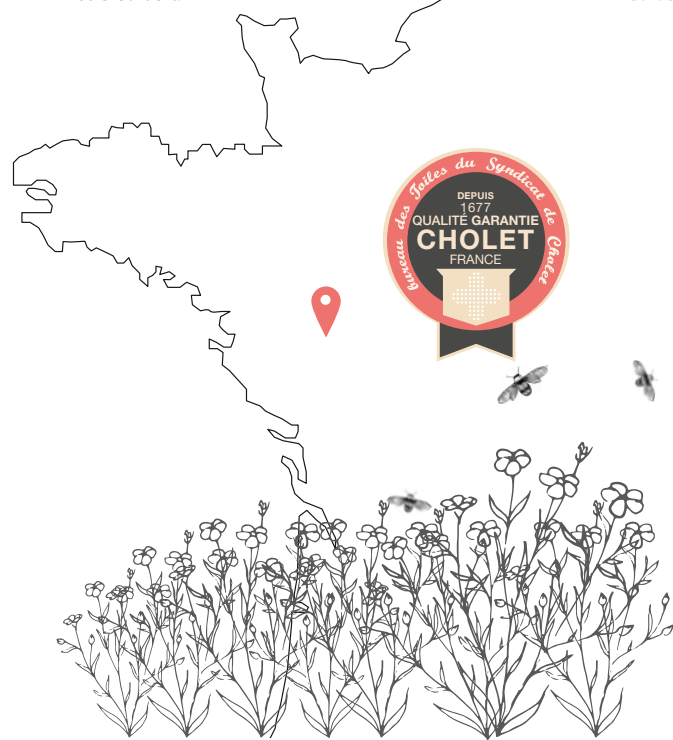

1819

Naissance d'Alexandre Turpault à Cholet, dernier d'une fratrie de 4 frères d'une famille de filateurs.

Birth of Alexandre Turpault in Cholet, the last in a line of four brothers born to a family of spinners.



1838

A 19 ans, Alexandre s'associe avec ses frères et son beau-père pour exploiter l'atelier de filature et la blanchisserie.

At 19 years of age, Alexandre joins his brothers and stepfather in running and operating the family's spinning workshop and laundry.



1847

Naissance de la société qui porte encore son nom aujourd'hui. Il est le premier à mécaniser les métiers à tisser avec une motorisation animée par l'énergie à vapeur. C'est aussi la première entreprise avec intégration verticale en linge de maison, alliant teinture du fil à la broderie des monogrammes.



Birth of the business that still carries his name today. Alexandre Turpault becomes the first company to use steam-driven engines to mechanise the various weaving trades. It's also the first to employ vertical integration in household linen production, thus bringing together the processes of thread dyeing and monogram embroidery.

VERS 1860

"LE MOIS DU BLANC" naît d'une rencontre entre Aristide Boucicaut, fondateur du Bon Marché, et Alexandre Turpault.

AROUND 1860

"LE MOIS DU BLANC" (Month of White) is born out of a meeting between Aristide Boucicaut, founder of Bon Marché, and Alexandre Turpault.

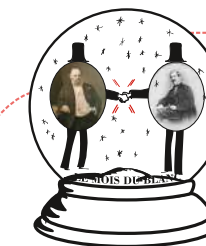

Le Mois du Blanc, fut organisé au mois de janvier, un mois traditionnellement dédié à la lessive et au renouvellement des textiles de maison, de plus il était nécessaire de regarnir les rayons vidés après les ventes de Noël, enfin il s'agissait de créer du trafic en magasin afin d'animer une période morte juste après les fêtes.

The Mois du Blanc was organised and held for the very first time in the month of January, a month traditionally dedicated to laundering and the replacement/renewal of household textiles. There was also a need at this time of year to restock shelves left empty after the Christmas trading season, and to increase traffic to the store to boost business in the slow period following the Christmas and New Year celebrations.

« La beauté se juge au premier coup d'oeil

"Beauty can be judged at first glance,

mais la qualité se révèle à l'usage. »

but quality reveals itself with use"

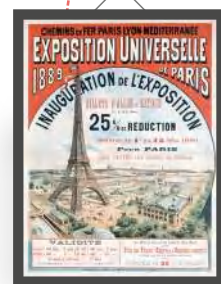

1889

Durant l'Exposition Universelle, la maison Alexandre Turpault reçoit la médaille d'or pour la qualité de ses toiles fines et leur prix raisonnable. Alexandre Turpault est fait chevalier de la légion d'honneur.

At the Paris Exposition Universelle (World's Fair), Alexandre Turpault's company is awarded the médaille d'or (gold medal) for the quality of its fine linens and their reasonable pricing. Alexandre Turpault is made chevalier de la légion d'honneur (Knight of the Legion of Honour).

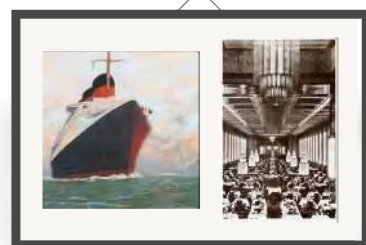

Alexandre Turpault est sélectionné dans les années 30 pour fournir les salles à manger du fameux paquebot «Le Normandie», fleuron du luxe à la Française.

Alexandre Turpault is selected to furnish the dining rooms of the famous ocean liner Le Normandie, the emblematic flagship of French style luxury.

1930

La maison emploie plus de 3000 ouvriers et fournit les meilleurs magasins avec son linge fin.

The company now employs a workforce of 3,000 and supplies its fine linens to the very best stores.



1997

Une famille des Flandres - les Vanderschooten, tisseurs réputés depuis plusieurs générations - rachète aux héritiers d'Alexandre Turpault la société.

A family from Flanders - the Vanderschooten, highly regarded weavers for several generations - purchase the company from Alexandre Turpault's heirs.

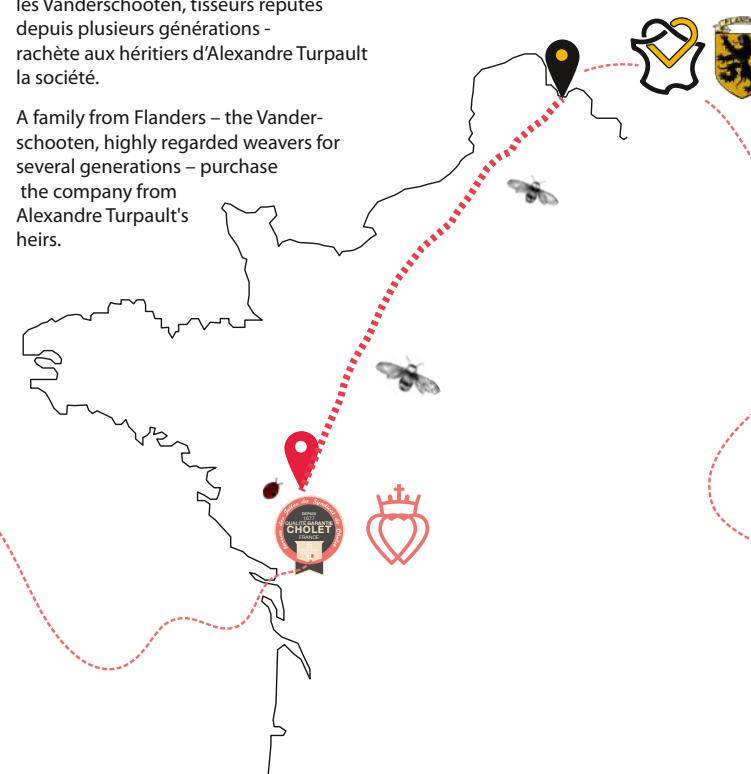

2017

170 printemps, été, automne... et toujours le désir de vous faire rêver. Alexandre Turpault ouvre le premier concept store de son histoire à Saint-Germain-des-Près.

One hundred and seventy springs, summers, autumns... and still the desire and determination to enthral you and fuel your imagination. Alexandre Turpault opens its very first concept store in Saint-Germain-des-Près, Paris.



2022

Collection Printemps | Été "Dans mon jardin"



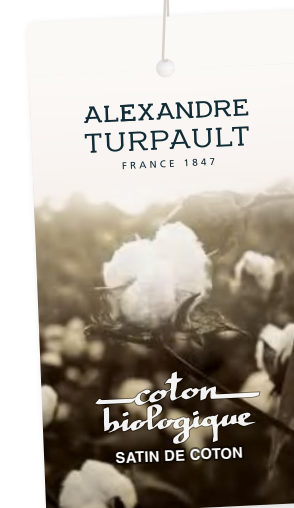

## Coton biologique

## Organic cotton

### LIT SATIN ET JACQUARD DE COTON

Satin de coton Bio peigné longues fibres 120fils/cm<sup>2</sup>  
Jacquard de coton Bio peigné longues fibres 120fils/cm<sup>2</sup>

La qualité est une constante de la marque  
**ALEXANDRE TURPAULT**.

Elle se retrouve dans le choix des plus belles  
**MATIERES** pour un linge de lit haut de gamme,  
conçu pour durer et pour être transmis aux  
générations futures.

Pour notre coton nous faisons le choix d'un  
produit éthique sans risque pour la santé, ni pour  
l'environnement.

Le coton biologique que nous utilisons est issu de  
l'agriculture biologique.

Il ne consomme pas de pesticides, pas d'engrais  
chimiques et beaucoup moins d'eau que les cultures  
conventionnelles intensives.

Les cotons bio sont non OGM.

La finition ruban de satin du TEOPHILE est tissée  
en France à partir de coton biologique pour un  
produit 100% vertueux.

Les emballages ont été conçus pour être  
entièrement recyclables, papiers, encre végétales,  
liens et pochons en coton bio sont réutilisables.

### COTTON SATEEN AND JACQUARD BED LINEN

Organic combed long fibres cotton sateen 300TC  
Organic combed long fibres cotton jacquards 300TC

Quality remains a constant value for the  
**ALEXANDRE TURPAULT** brand.

Quality is best expressed in the selection of the  
most beautiful **MATERIAL** destined to our fine  
bed linens.

Our Linens have enduring qualities and are meant  
to be passed as an heirloom from generation to  
generation. We have an ethical commitment to  
provide the best products offering positive values  
to humans while remaining eco-friendly.

Our organic cotton is cultivated through  
biological agriculture. It means that there is no  
use of pesticides and chemical fertilizers, much  
less consumption of water than in intensive  
conventional agriculture.

Organic cottons are GMO free.

TEOPHILE is finished with satin ribbons made of  
organic cotton and woven in France as to complete  
our virtuous cycle.

Packaging has been conceived as a cradle to  
cradle project with recycled paper and vegetal  
inks, ribbons and textile bags are reusable and  
ready for a second life.

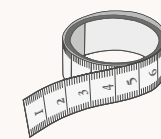

Service sur mesure : dimensions spéciales  
sur tarif ou sur simple demande.

Custom size service : quotation available  
on price list or upon request.

Teophile	6	Chandernagor	16
Marceau	10	<b>Envolée</b> <sup>NEW</sup>	17
Orsay	12	Halatte	18
<b>À la belle étoile</b> <sup>NEW</sup>	14	Octobre	19
Blossom	15		



# Teophile

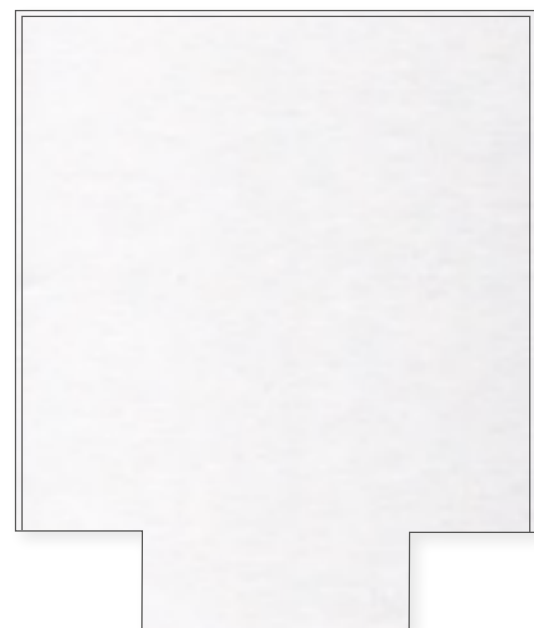

## HOUSSE DE COUETTE

Housse de couette unie, bordée d'un ruban satin de coton bio

## DUVET COVER

Plain dye with organic cotton sateen ribbon

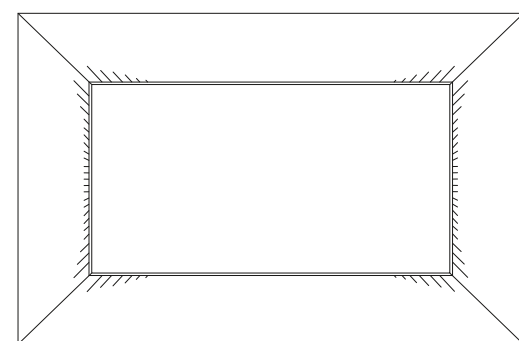

## DRAP HOUSSE\*

Profondeur de bonnet 30cm  
\*Profondeur de bonnet 40cm dans une sélection de coloris (neige) et de taille (160x200, 180x200)

## FITTED SHEET\*

Pocket depth 12"  
\*Pocket depth 16" available in a selection of colours (snow) and size (63x79, 71x79")

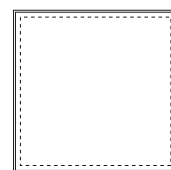

## TAIE

Taie unie, bordée d'un ruban satin de coton bio, Volant de 2cm

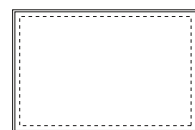

## PILLOWCASE

Plain dye, with organic cotton sateen ribbon, 0.8" flange

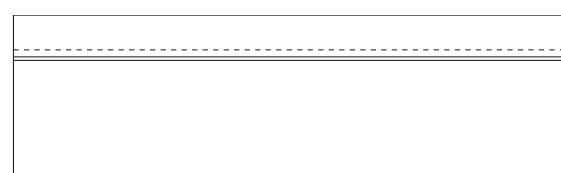

## DRAP

Drap uni, parement de 15cm bordé d'un ruban satin de coton bio

## FLAT SHEET

6" plain dye border with organic cotton sateen ribbon

Uni, satin de coton Bio, bordé d'un ruban de satin de coton bio  
Plain dye organic cotton sateen, organic cotton sateen ribbon



TEOPHILE baltique / baltic blue

Made in Italy

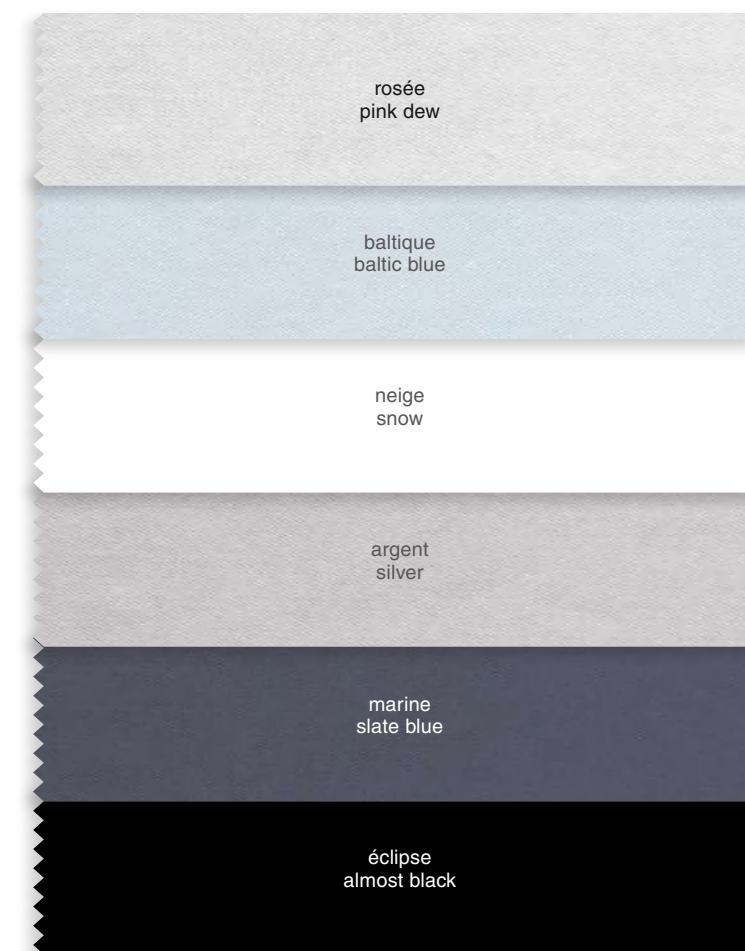
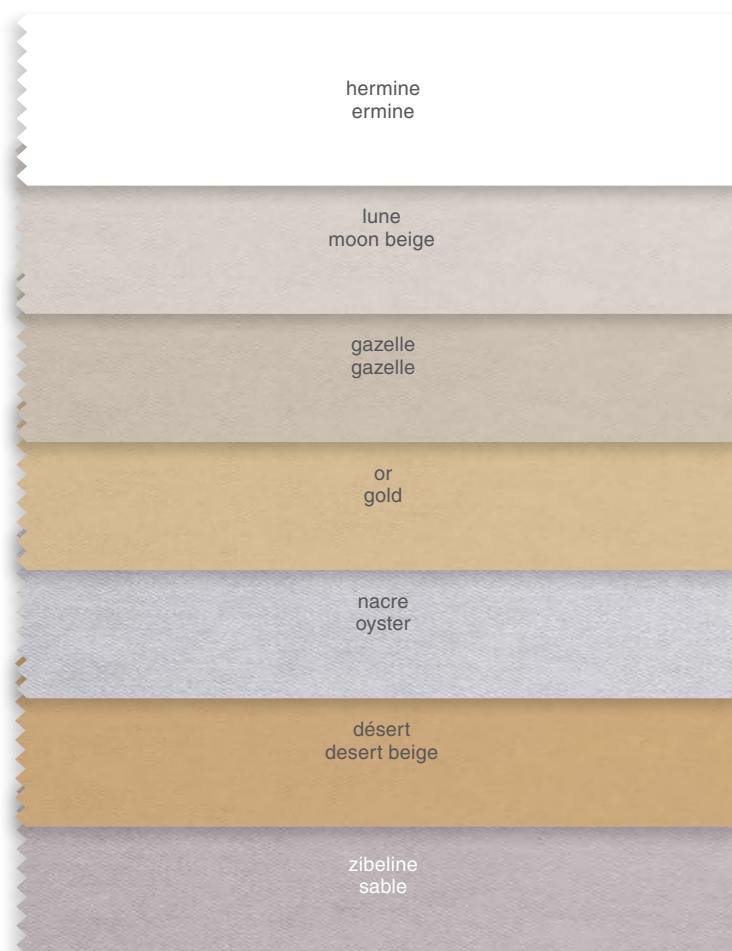



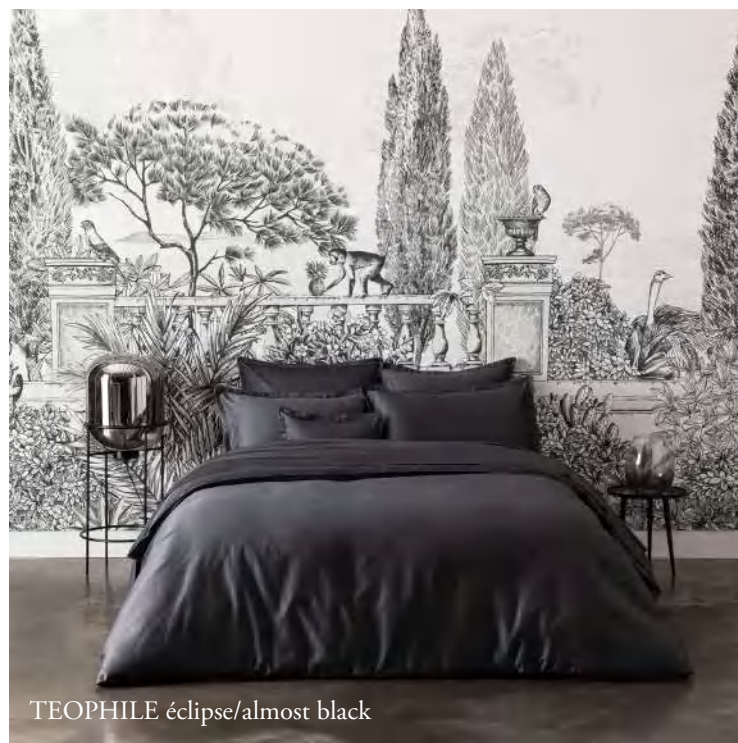

TEOPHILE éclipse/almost black



TEOPHILE argent/silver grey



TEOPHILE marine / slate blue



TEOPHILE argent/silver grey



TEOPHILE marine / slate blue



TEOPHILE neige / snow



# Marceau

Tricolore avec bande appliquée  
Three tone with appliqué tape.



MARCEAU NEIGE / MARINE / CINABRE 448  
MARCEAU SNOW / SLATE BLUE / CINABRE 448

Made in Italy

## UNIS COORDONNÉS / COORDINATED COLOURS



Teophile neige  
Teophile snow

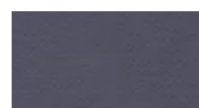

Teophile marine  
Teophile slate blue

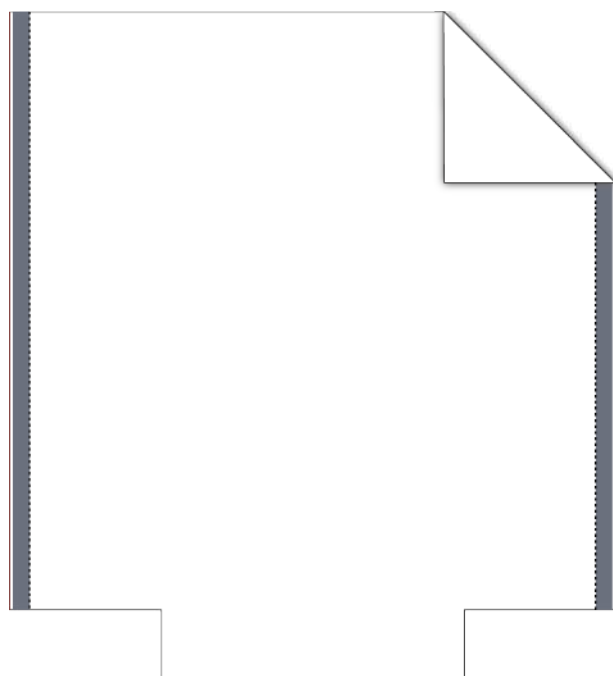

### HOUSSE DE COUETTE

Corps uni, Volants latéraux 5,5 cm avec bandes appliquées 4,5cm, insertion ruban tressé en bord.

### DUVET COVER

Plain dye body, 2,15" side flange with 1,75" appliqué tape, braided piping at the edge.

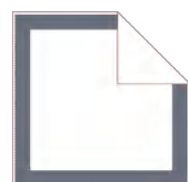

### TAIE

Corps uni, Volant piqués 5,5cm avec bandes appliquées 4,5cm en encadré, Coins capuchons, insertion ruban tressé au bord, dos uni, simple rabat.



### PILLOWCASE

Plain dye body, Frame made of a 2,15" flange with 1,75" appliqué tape, mitred corners, braided piping, plain dye in the back, single flap.

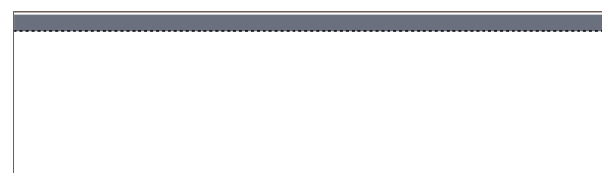

### DRAP

Corps uni, bandes appliquées 4,5cm, insertion ruban tresse.

### FLAT SHEET

Plain dye body, 1,7" appliqué tape frame, braided piping.

## Programme de Personnalisation | Personalization Program

1

### CORPS / BODY



#### COULEUR DU CORPS

Sélectionner dans la palette de couleurs, le coloris principal pour le corps du produit, face et dos identiques.

#### BODY COLOUR

Choose from the colour palette, the main colour for the body, face and reverse identical.

2

### COULEUR DE LA BANDE / APPLIQUÉ TAPE

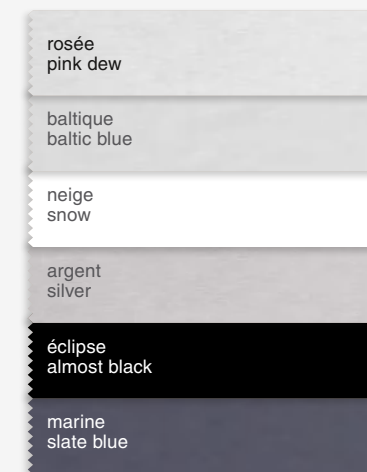

#### BANDES APPLIQUÉES

Sélectionner dans la palette de couleur, le coloris des bandes appliquées (1 seul coloris par produit)

#### APPLIQUÉ TAPE

Choose from the Colour Palette, the colour for the Appliqué Tape (1 single colour per product)

3

### LA TOUCHE FINALE : LE PASSEPOIL / THE FINAL TOUCH: THE PIPING

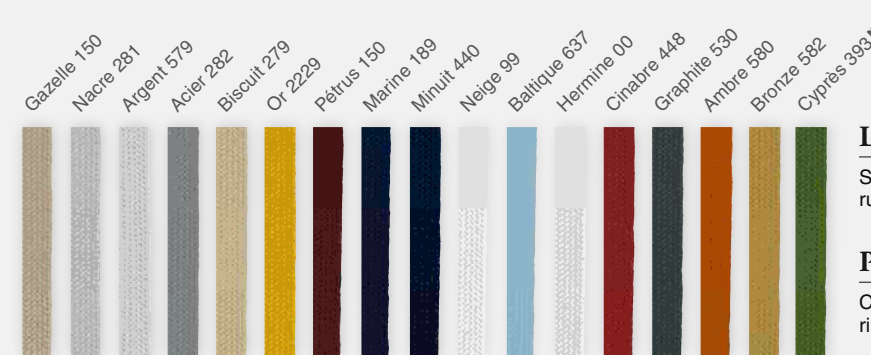

#### LE PASSEPOIL

Sélectionner dans la palette de coloris le ruban tressé à insérer en finition.

#### PIPING

Choose from the colour palette the braided ribbon to be inserted.



# Orsay

Jacquard de coton Bio "Piqué Cravate" et satin de coton Bio uni.  
Organic cotton "huckaback" jacquard with organic cotton plain dye sateen



ORSAY MARINE 189

Made in Portugal



ORSAY BLANC CYPRÈS 393

Made in Portugal

## COULEUR EN COLLECTION / COLOUR IN COLLECTION



Orsay Marine 189

## UNIS COORDONNÉS / COORDINATED COLOURS



Teophile neige  
snow



### HOUSSE DE COUETTE

Face corps jacquard "Piqué Cravate", parement haut 80cm satin uni avec insertion de ruban tressé, dos satin uni.

### DUVET COVER

"Huckaback" jacquard body in Front, top face band 31.5" of plain sateen with braided ribbon piping, reversing to plain dye sateen.

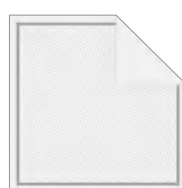

### TAIE VOLANT

Corps satin uni, plateau rapporté jacquard "Piqué Cravate". Volant uni de 3cm, ruban tressé inséré entre les 2 tissus, double rabat.



### PILLOWCASE (OXFORD)

Plain dye sateen body, appliqué "huckaback" jacquard in front. 1.18" flange, braided ribbon insert, double flap.

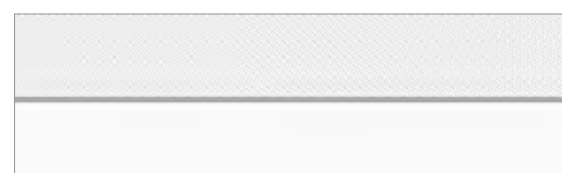

### FLAT SHEET

Plain dye sateen body, "Huckaback" jacquard 6" flange, braided ribbon insert.

## Programme de Personnalisation | Personalization Program

1

### VOTRE COLORIS DE PASSEPOIL / YOUR PIPING COLOUR



#### PASSEPOIL

Sélectionner dans la palette de coloris le ruban tressé à insérer en finition.

#### PIPING

Choose from the colour palette the braided ribbon to be inserted.

2

### TAIE SAC OU TAIE VOLANT / HOUSEWIFE OR OXFORD PILLOWCASE

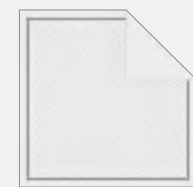

#### TAIE SAC

Face jacquard "Piqué Cravate", dos et parement satin uni 15cm pour taies 65x65 et 18cm pour taie 50x75. Ruban tressé inséré entre les 2 tissus, double rabat.

#### PILLOWCASE (HOUSEWIFE)

"Huckaback" jacquard in front, back and side flange in plain dye sateen 5,9" for the square PC and 7" for the rectangular PC. in plain dye sateen. Braided ribbon insert, double flap.



# À la belle étoile

Satin de coton Bio imprimé "À la belle étoile"  
Organic cotton printed sateen "under the stars"

NEW



Made in Italy

## ACCESSOIRES ET UNIS COORDONNÉS / COORDINATED ACCESSORIES AND COLOURS



Loulou hermine  
ermine



Merveille gazelle / hermine  
gazelle / ermine



Teophile lune  
moon beige

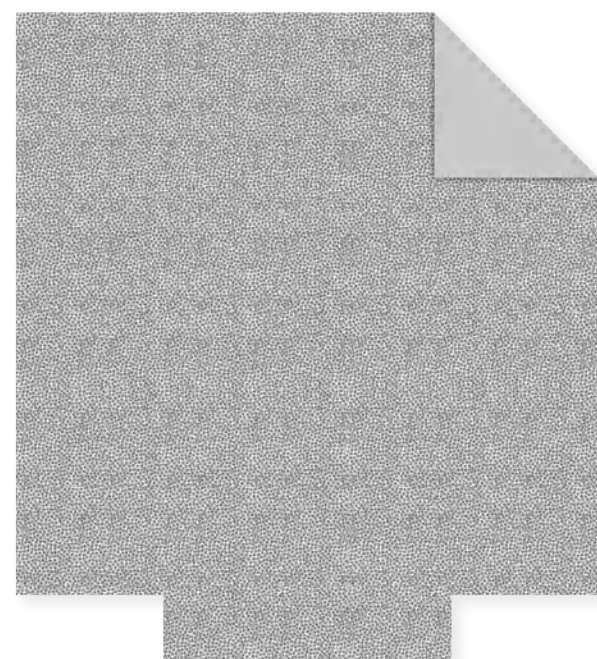
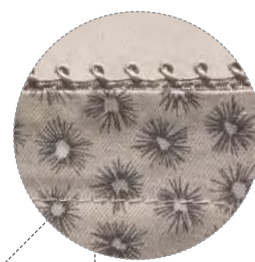

### HOUSSE DE COUETTE

Face imprimée "À la belle étoile", dos satin uni lune.

### DUVET COVER

"Under the stars" printed body, reversing to plain dye sateen.

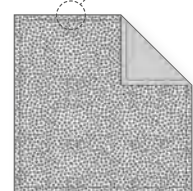

### TAIE

Face imprimée "À la belle étoile", dos satin uni. Volant piqué 2cm, ruban picot inséré en bordure, double rabat.

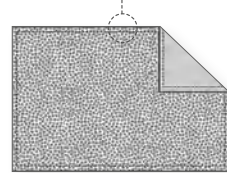

### PILLOWCASE (OXFORD)

"Under the stars" pattern in front reversing to plain dye sateen. 0,8" flange, Picot ribbon piping, double flap.

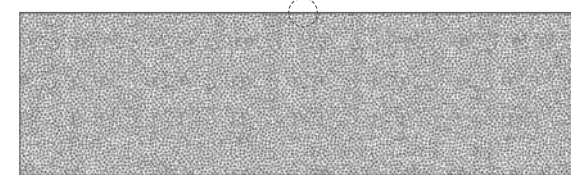

### FLAT SHEET

"Under the stars" printed body, Picot ribbon piping at the top edge.

Corps imprimé "À la belle étoile", ruban picot inséré en bord de drap.

### DRAP

# Blossom

Satin de coton Bio imprimé "Passiflore"  
Organic cotton printed sateen "Passionflower"



Made in Italy

## ACCESSOIRES ET UNIS COORDONNÉS / COORDINATED ACCESSORIES AND COLOURS



Velin praline



Loulou hermine  
ermine



Teophile neige  
snow



Teophile rosée  
pink dew

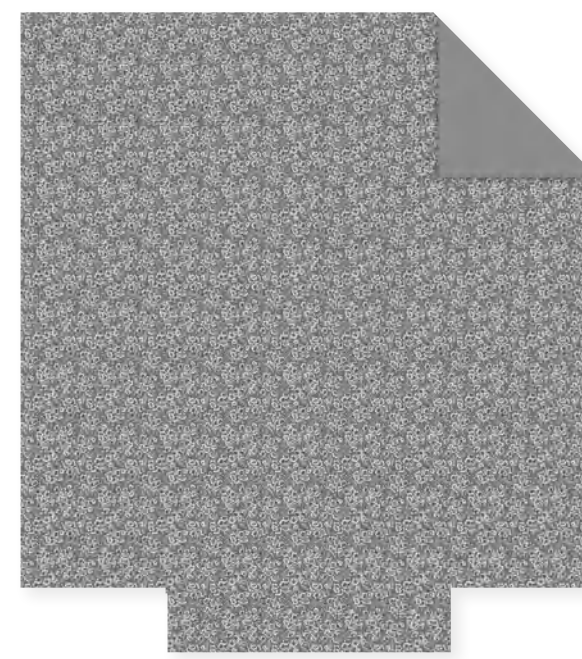

### HOUSSE DE COUETTE

Face imprimée "Passiflore", dos satin uni rosée.

### DUVET COVER

"Passionflower" printed body, reversing to plain dye pink dew sateen.

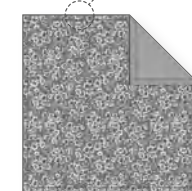

### TAIE

Face imprimée "Passiflore", dos satin uni rosée. Volant piqué 2cm, ruban Picot inséré en bordure, double rabat

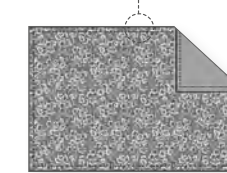

### PILLOWCASE (OXFORD)

"Passionflower" pattern in front reversing to plain dye pink dew sateen. 0.8" flange, Picot ribbon piping, double flap.

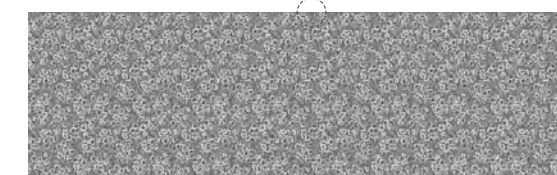

### FLAT SHEET

"Passionflower" printed body, Picot ribbon piping at the top edge.

Corps imprimé "Passiflore", ruban Picot inséré en bord de drap.

### DRAP



# Chandernagor

Satin de coton Bio imprimé "Perse"  
Organic cotton printed sateen "Persia"



Made in Italy

## ACCESSOIRES ET UNIS COORDONNÉS / COORDINATED ACCESSORIES AND COLOURS



Loulou hermine



poesie marine slate blue



Teophile neige snow



Teophile marine slate blue

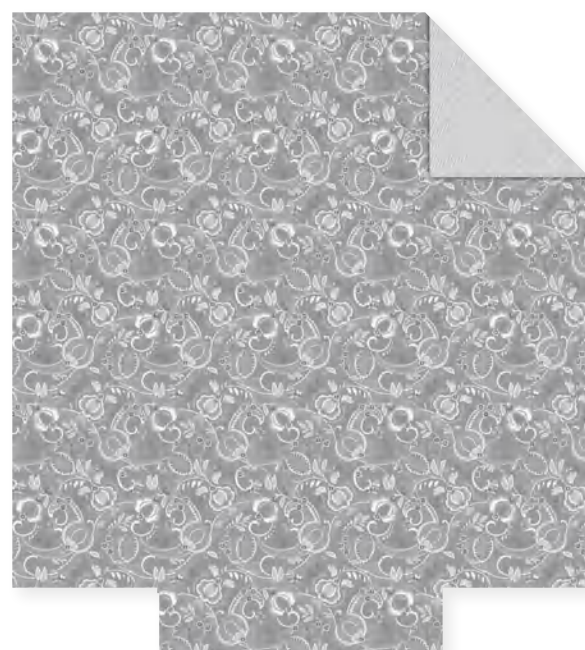

### HOUSSE DE COUETTE

Face imprimée "Perse", dos imprimé "micro motif".

### DUVET COVER

"Persia" printed body, reversing to "micro pattern" print.



### TAIE

Face imprimée "Perse", dos imprimé "micro motif".  
Volant piqué 3cm ruban satin inséré en bordure, double rabat.



### PILLOWCASE (OXFORD)

"Persia" pattern in front reversing to "micro pattern" print.  
1,18" flange, satin ribbon piping, double flap.



### FLAT SHEET

"Persia" printed body, satin ribbon piping at the top edge.

### DRAP

Corps imprimé "Perse", ruban satin inséré en bord de drap.

# Envolée

Satin de coton Bio imprimé "Souffle de verdure"  
Organic cotton printed sateen "Airy greenery"



Made in Italy

## ACCESSOIRES ET UNIS COORDONNÉS / COORDINATED ACCESSORIES AND COLOURS



Loulou eucalyptus



poesie neige snow white



Teophile neige snow

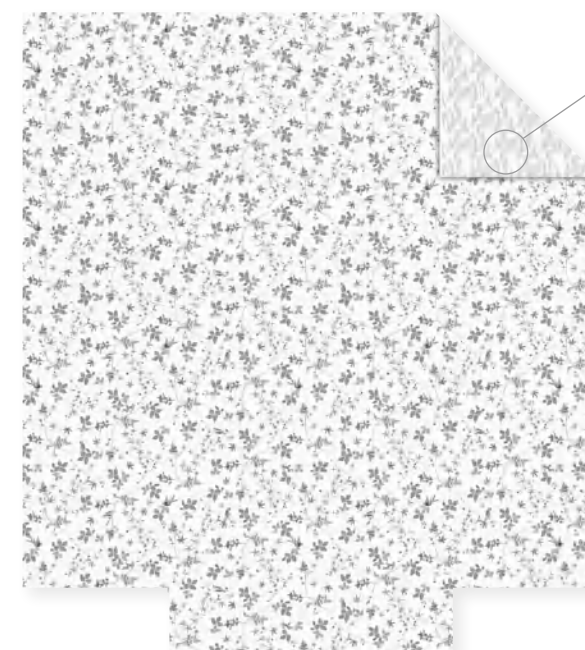

### HOUSSE DE COUETTE

Face imprimée "Souffle de verdure", dos imprimé "ikat".

### DUVET COVER

"Airy greenery" printed body, reversing to printed sateen "ikat".

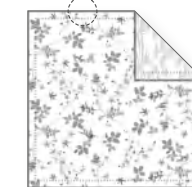

### TAIE

Face imprimée "Souffle de verdure", dos imprimé "ikat".  
Volant piqué 3cm, ruban tressé inséré en bordure, double rabat.

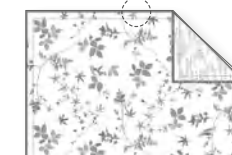

### PILLOWCASE (OXFORD)

"Airy greenery" pattern in front reversing to printed sateen "ikat".  
1,2" flange, braided ribbon piping, double flap.

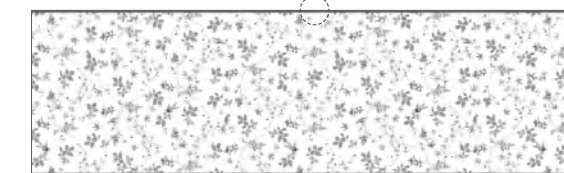

### FLAT SHEET

"Airy greenery" printed body, braided ribbon piping at the top edge.

### DRAP

Corps imprimé "Souffle de verdure", ruban tressé inséré en bord de drap.



# Halatte

Satin de coton Bio imprimé "Forêt d'Automne"  
Organic cotton printed sateen "Autumn Forest"



Made in Italy

## ACCESSOIRES ET UNIS COORDONNÉS / COORDINATED ACCESSORIES AND COLOURS



Nomade latte



Voltaire tourbe peat black



Teophile désert desert beige



Teophile lune moon beige

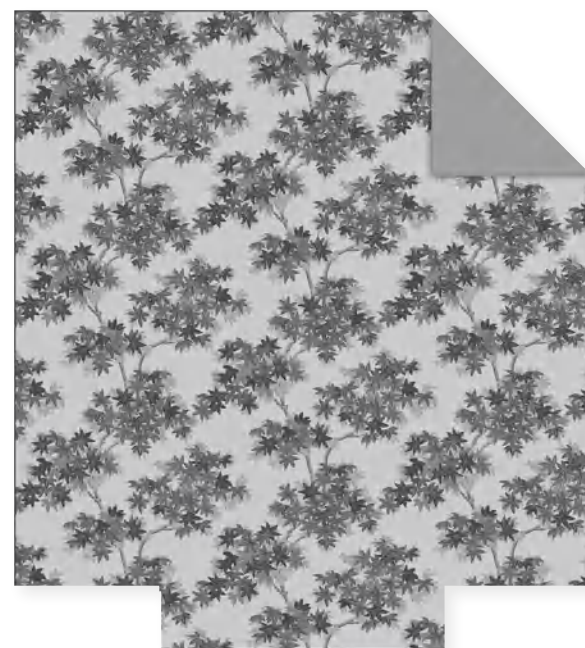

### HOUSSE DE COUETTE

Face imprimée "Forêt d'automne", dos satin uni désert.

### DUVET COVER

"Autumn forest" printed body, reversing to plain dye sateen.



### TAIE

Face imprimée "Forêt d'automne", dos satin uni. Volant piqué 3cm, ruban satin de coton inséré en bordure, double rabat.



### PILLOWCASE (OXFORD)

"Autumn forest" pattern in front reversing to plain dye sateen. 1.2" flange, cotton satin ribbon piping, double flap.



### DRAP

Corps imprimé "Forêt d'automne", ruban satin de coton inséré en bord de drap.

### FLAT SHEET

"Autumn forest" printed body, cotton satin ribbon piping at the top edge.

# Octobre

Jacquard de coton Bio "branches de cerisiers"  
Organic cotton Jacquard "cherry trees"



Made in Italy

## ACCESSOIRES ET UNIS COORDONNÉS / COORDINATED ACCESSORIES AND COLOURS



Loulou hermine



Voltaire nuage cloud grey



Teophile lune moon beige

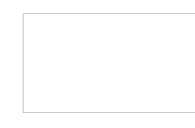

Teophile hermine

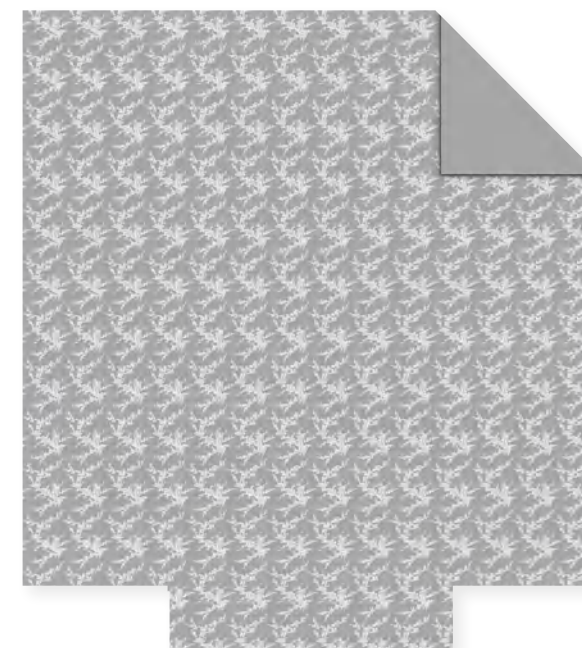
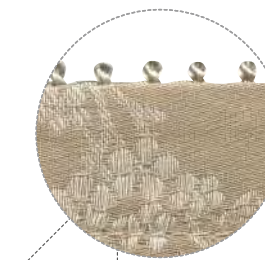

### HOUSSE DE COUETTE

Face jacquard motifs "Branches de cerisiers", dos satin uni lune.

### DUVET COVER

"Cherry trees" jacquard pattern body, reversing to plain dye sateen.

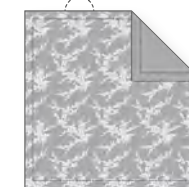

### TAIE

Face jacquard motifs "branches de cerisiers", dos satin uni. Volant piqué 2cm, ruban picot inséré en bordure, double rabat.

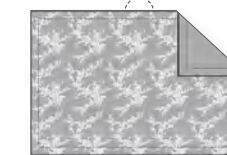

### PILLOWCASE (OXFORD)

"Cherry trees" jacquard pattern in front reversing to plain dye sateen. 0.8" flange, picot ribbon piping, double flap.

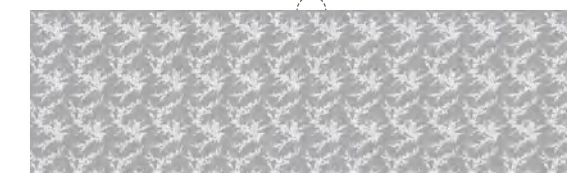

### DRAP

Corps jacquard motifs "Branches de cerisiers", ruban picot inséré en bord de drap.

### FLAT SHEET

Full body jacquard pattern "Cherry trees", picot ribbon piping at the top edge.



# ALEXANDRE TURPAULT

FRANCE 1847

## Lit satin

**ALEXANDRE TURPAULT** vous présente sa collection de linge de lit en pur coton :

Du satin de coton peigné 120 fils/cm<sup>2</sup>, dont la fibre de qualité supérieure amène plus de douceur et de brillance.

Travaillés chez les meilleurs maîtres imprimeurs Italiens, nos motifs sont d'une finesse exceptionnelle.

Afin de vous donner entière satisfaction, tous nos tissus sont testés rigoureusement pour vous garantir la meilleure qualité.

## Cotton sateen

**ALEXANDRE TURPAULT** presents his pure cotton bed range :

300 tc / inch cotton sateen. Its natural fibre is of exceptional quality. The sateen weave gives it greater softness and sheen.

Printed by the best Italian suppliers, our printed cotton sateen has an exceptional fineness.

In order to ensure your complete satisfaction, all our fabrics and items are rigorously tested to guarantee you the best quality.

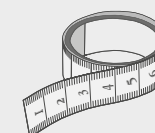

Service sur mesure : dimensions spéciales sur tarif ou sur simple demande.

Custom size service : quotation available on price list or upon request.

Canopée  
Quintessence  
Namaste

22  
23  
24-25



# Canopée

Satin imprimé "Canopée"  
Printed sateen "Canopy"



ACCESSOIRES ET UNIS COORDONNÉS / COORDINATED ACCESSORIES AND COLOURS



poesie baltique  
baltic blue



poesie neige  
snow white



Teophile neige  
snow



Teophile baltique  
baltic blue

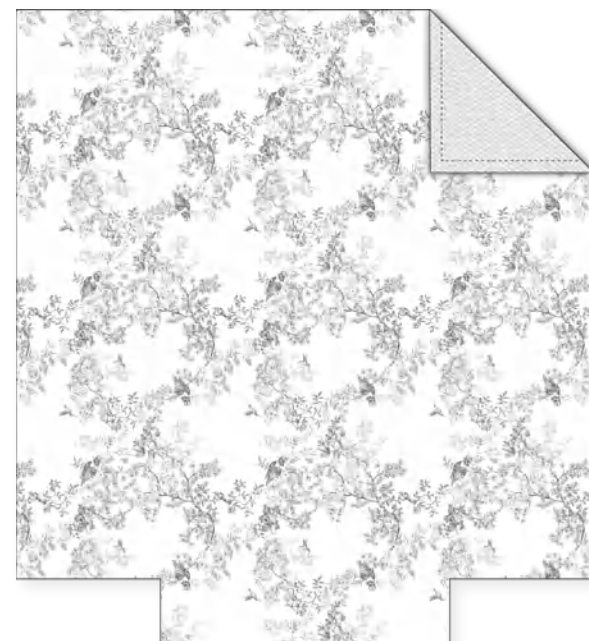

**HOUSSE DE COUETTE**

Face imprimée "Canopée", dos imprimé "Ikat".

**DUVET COVER**

"Canopy" printed body, reversing to "Ikat" print.



**TAIE**

Face imprimée "Canopée", dos imprimé "Ikat".  
Volant piqué 2cm, ruban Gros Grain inséré en bordure, double rabat.

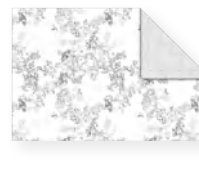

**PILLOWCASE**

"Canopy" pattern in front, reversing to "Ikat" print.  
0,8" flange, Gros Grain ribbon piping, double flap.



**FLAT SHEET**

"Canopy" printed body, Gros Grain ribbon piping at the top edge.

# Quintessence

Satin imprimé "Arbre de Vie"  
Printed sateen "Tree of Life"



ACCESSOIRES ET UNIS COORDONNÉS / COORDINATED ACCESSORIES AND COLOURS



poesie rosée  
pink dew



Loulou rosée  
Loulou pink dew

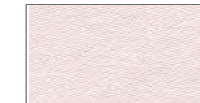

Teophile rosée  
pink dew



Teophile or  
gold



**HOUSSE DE COUETTE**

Face imprimée "Arbre de Vie", dos imprimé "Ikat".

**DUVET COVER**

"Tree of Life" printed body, reversing to "Ikat" print.



**TAIE**

Face imprimée "Arbre de Vie", dos imprimé "Ikat".  
Volant piqué 3cm, insertion ruban tressé, double rabat.



**PILLOWCASE**

"Tree of Life" pattern in front, reversing to "Ikat" print.  
1,2" flange, Braided piping, double flap.



**DRAP**

Corps imprimé "Arbre de Vie", insertion ruban tressé au bord du drap.

**FLAT SHEET**

"Tree of Life" printed body, braided piping at the top edge.



# Namaste ARGENT / SILVER



# Namaste NEIGE / SNOW



Made in Italy

ACCESSOIRES ET UNIS COORDONNÉS / COORDINATED ACCESSORIES AND COLOURS



argent silver



Teophile argent silver



Nomade gris grey



blanc white

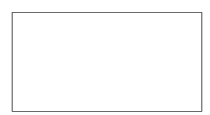

Teophile neige snow

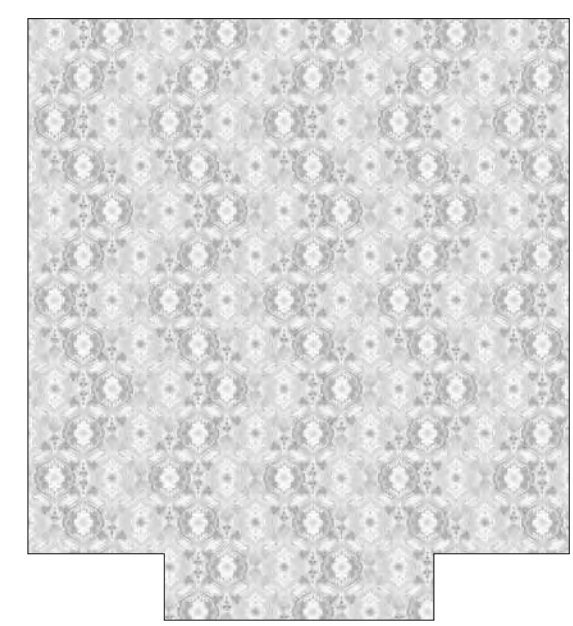

**HOUSSE DE COUETTE**

Face et dos imprimés « Cachemire »

**DUVET COVER**

Printed « Cashmere » on both sides



**TAIE**

Face et dos imprimés « Cachemire »  
bordée d'un ruban satin,  
Volants de 2 cm

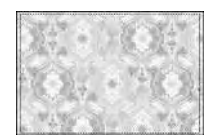

**PILLOWCASE**

Printed « Cachemire » on both sides  
0,8" flange  
satin ribbon piping

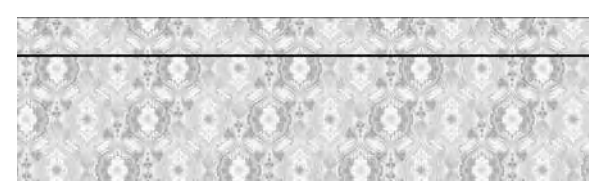

**DRAP**

Corps imprimé « Cachemire »  
parement de 15cm  
bordé d'un ruban de satin

**FLAT SHEET**

Printed « Cashmere »  
6" border  
satin ribbon piping

# Namaste BISCUIT



Made in Italy

ACCESSOIRES ET UNIS COORDONNÉS / COORDINATED ACCESSORIES AND COLOURS



Biscuit



Teophile lune moon beige



Nomade beige



Tsarine zibeline sable

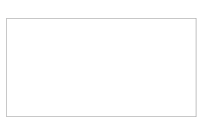

Teophile hermine ermine





# ALEXANDRE TURPAULT

FRANCE 1847

## Lit percale de coton

**ALEXANDRE TURPAULT** vous présente sa collection de linge de lit en percale coton 80 fils/cm<sup>2</sup>.

Sa fibre longue et son armure toile serrée lui apportent finesse et résistance.

Afin de vous donner entière satisfaction, tous nos tissus et articles sont testés rigoureusement pour vous garantir la meilleure qualité.

Travaillés chez les meilleurs maîtres imprimeurs Italiens, nos motifs sont d'une finesse exceptionnelle.

Afin d'en faciliter l'entretien, la percale bénéficie d'un traitement « Easy care ».

Une finition « Sanfor » apporte plus de douceur et de souplesse.

## Cotton percale bedlinen

**ALEXANDRE TURPAULT** presents his pure cotton percale range in 200 tc cotton percale.

Its long fibres and tight plain weave give it delicacy and resistance over time.

In order to ensure your complete satisfaction, all our fabrics and items are rigorously tested to guarantee you the best quality.

Printed by the best Italian suppliers, our designs have an exceptional delicacy.

Our percale benefits from an « Easy care » treatment as well as a « Sanfor » finish for softer and smoother hand.



Touché plus doux  
Soft touch

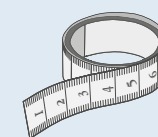

Service sur mesure : dimensions spéciales sur tarif ou sur simple demande.

Custom size service : quotation available on price list or upon request.

**Baroque**<sup>NEW</sup>  
Candide

28  
29

Sous-bois  
Trésor

30  
31



# Baroque

Percale imprimée "Ananas et fleurs baroques"  
Printed percale "baroque flowers and pinapples"

NEW



Made in Italy

# Candide

Percale imprimée "Flore persane"  
Printed percale "Persian Flora"



Made in Italy

## ACCESSOIRES ET UNIS COORDONNÉS / COORDINATED ACCESSORIES AND COLOURS



Loulou hermine  
ermine



Merveille désert/lune  
antic gold/moon beige

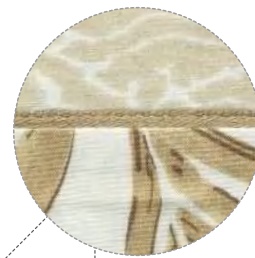

### TAIE

Face imprimée "Ananas et fleurs baroques", dos imprimé "effet de moire". Volant piqué 3cm, passepoil, double rabat.

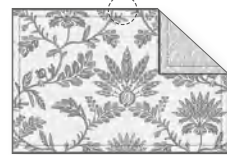

### PILLOWCASE (OXFORD)

"baroque flowers and pinapples" pattern in front reversing to printed "moire effect". 1.2" flange, piping, double flap.



### HOUSSE DE COUETTE

Face imprimée "Ananas et fleurs baroques", dos imprimé "effet de moire".

### DUVET COVER

"baroque flowers and pinapples" printed body, reversing to printed "moire effect".

### DRAP

Corps imprimé "Ananas et fleurs baroques", passepoil inséré en bord de drap.

### FLAT SHEET

"baroque flowers and pinapples" printed body, piping at the top edge.

## ACCESSOIRES ET UNIS COORDONNÉS / COORDINATED ACCESSORIES AND COLOURS



Nouvelle vague eucalyptus



Loulou eucalyptus



Teophile neige  
snow

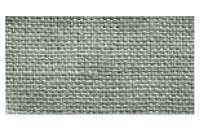

Nouvelle vague eucalyptus

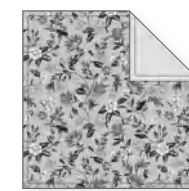
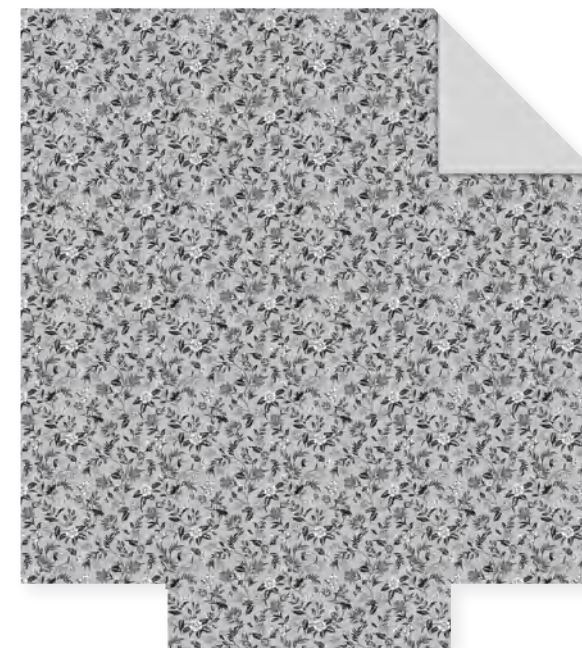

### TAIE

Face imprimée "Flore persane", dos imprimé "petits traits". Volant piqué 2cm, passepoil, double rabat.

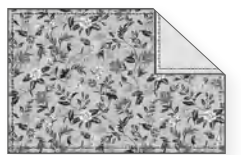

### PILLOWCASE (OXFORD)

"Persian flora" pattern in front reversing to printed "small lines". 0.8" flange, piping, double flap.



### HOUSSE DE COUETTE

Face imprimée "Flore persane", dos imprimé "petits traits".

### DUVET COVER

"Persian flora" printed body, reversing to printed "small lines".

### DRAP

Corps imprimé "Flore persane", passepoil inséré en bord de drap.

### FLAT SHEET

"Persian flora" printed body, piping at the top edge.



# Sous-bois

Percalle imprimée "Feuilles Art déco et motifs Ikat"  
Printed percale "Art Deco leaves and Ikat pattern"



LIT PERCALE DE COTON  
COTTON PERCALE BEDLINEN

# Trésor

Percalle imprimée "Tapis de fleurs"  
Printed percale "Flower carpet"



LIT PERCALE DE COTON  
COTTON PERCALE BEDLINEN

## ACCESSOIRES ET UNIS COORDONNÉS / COORDINATED ACCESSORIES AND COLOURS



Voltaire bruyère heather



Voltaire lichen



Teophile neige snow



Touché plus doux  
Soft touch



## ACCESSOIRES ET UNIS COORDONNÉS / COORDINATED ACCESSORIES AND COLOURS



Touché plus doux  
Soft touch



Nouvelle Vague naturel natural



Tsarine vison mink

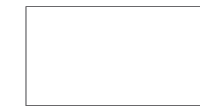

Teophile neige snow



Nouvelle Vague naturel natural

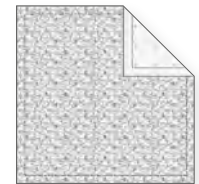
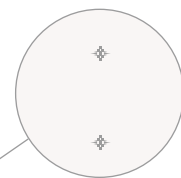
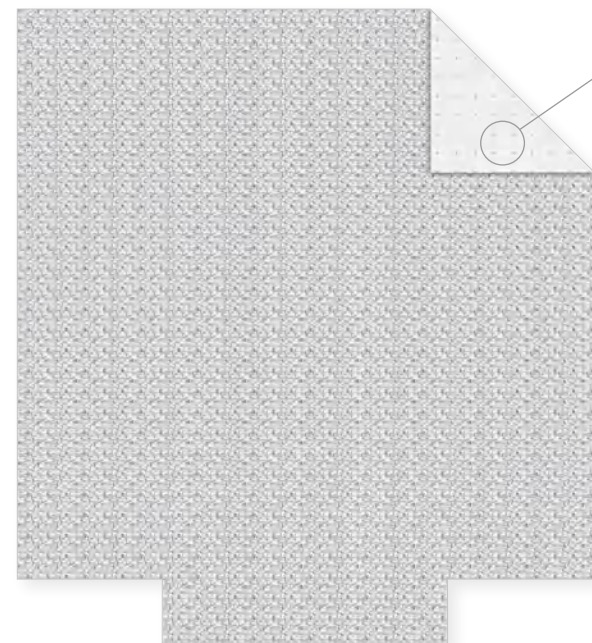
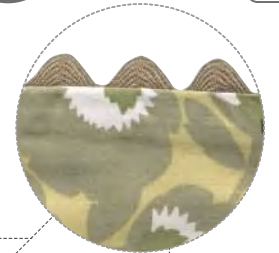

### TAIE

Face imprimée "Feuilles Art déco", dos imprimé "petit Ikat". Volant piqué 2cm, passepoil, double rabat.

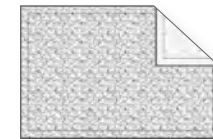

### PILLOWCASE (OXFORD)

"Art Deco leaves" pattern in front reversing to printed "small Ikat". 0.8" flange, piping, double flap.



### HOUSSE DE COUETTE

Face imprimée "Feuilles Art déco", dos imprimé "petit Ikat".

### DUVET COVER

'Art Deco leaves" printed body, reversing to printed "small Ikat".

### DRAP

Corps imprimé "Feuilles Art déco", passepoil inséré en bord de drap.

### FLAT SHEET

"Art Deco leaves" printed body, piping at the top edge.

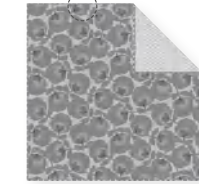
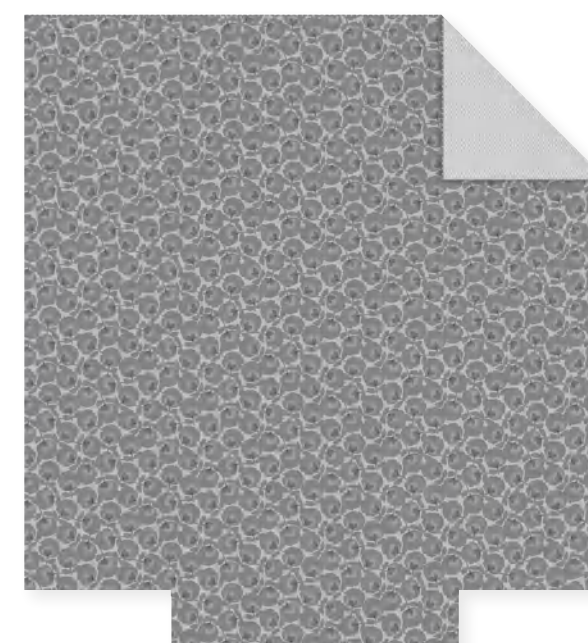

### TAIE

Face imprimée "Tapis de fleurs", dos imprimé "micro motif". Taie sac, ruban Croquet en passepoil, double rabat.

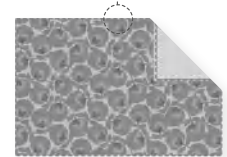

### PILLOWCASE

"Flower carpet" pattern in front reversing to printed "micro pattern". housewife pillowcase, Croquet ribbon pipping, double flap.

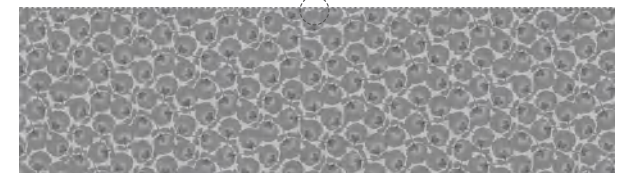

### HOUSSE DE COUETTE

Face imprimée "Tapis de fleurs", dos imprimé "micro motif".

### DUVET COVER

"Tapis de fleurs" printed body, reversing to printed "micro pattern".

### DRAP

Corps imprimé "Tapis de fleurs", ruban Croquet inséré en bord de drap.

### FLAT SHEET

"Flower carpet" printed body, Croquet ribbon at the top edge.





# ALEXANDRE TURPAULT

FRANCE 1847

Lin tissé et teint en FRANCE  
Linen woven and dyed in  
FRANCE

## Lit lin Pure linen bedlinen

Depuis l'origine, **ALEXANDRE TURPAULT**, spécialiste reconnu pour la qualité de ses toiles de lin fin, propose un circuit court pour son linge en lin, teillé, tissé, teint et confectionné en France.

C'est une approche unique, simple et sobre, en phase avec les valeurs de l'entreprise et son éthique de travail qui privilégie la responsabilité sociale et environnementale, le respect du vivant et l'attention à l'humain, l'exigence de la qualité jusque dans le détail, la fidélité au beau, au bon, à la nature.

Le lin longue fibre cultivé en France, est la matière reine du linge de lit. Il apporte un bien être incomparable, grâce à ses qualités thermorégulatrices et hypoallergéniques. Écologique par excellence, la plante de lin consomme peu d'eau, pas d'engrais ni de pesticides et enrichit les sols où elle pousse.

**ALEXANDRE TURPAULT** propose un vrai lin de qualité durable qui embellit et se bonifie au fil des lavages. Il se transmet aux nouvelles générations dans un cycle de consommation raisonnée et responsable.

La finesse de la toile et la beauté des finitions comme les Jours Venise, les jours échelles, les rubans tissés ou les petites guipures contribuent jour après jour au raffinement de l'art de vivre à la française et à cet amour du Beau qui nous rend heureux.

Since the beginning in 1847, **ALEXANDRE TURPAULT**, renowned specialist for the quality of his fine linens, offers a more direct production channel for his linen, scutched, woven, dyed and made in France.

It is a unique approach, simple and sober, in line with the values of the company and its work ethic which favours social and environmental responsibility, respect for the living and attention to the human, the requirement of quality up to the Detail, fidelity to beauty, to good, to nature.

The long flax fibre grown in France, is the best material for bed linen. It brings an incomparable well-being, thanks to its thermoregulating and allergy free qualities. Ecological par excellence The flax plant, consumes little water, no fertilizers or pesticides and enriches the soils.

**ALEXANDRE TURPAULT** offers a real durable quality flax that embellishes and improves over the washing. It is handed down to the new generations in a cycle of reasoned and responsible consumption.

The fine cloth, subtle colours, the supple hand feel and the beauty of finishings like Venetian lace, the open work stitches, woven ribbons or little lace detail contribute day after day to the refinement embodied in the French Art of living. Our passionate search for Beauty that bring us Joy.

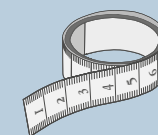

Service sur mesure : dimensions spéciales sur tarif ou sur simple demande.  
Custom size service : quotation available on price list or upon request.

Cythère	34	Bastide	40
Maine	35	Keops	41
<b>Nouvelle Vague</b> <sup>NEW</sup>	<b>36-39</b>	Régence	42



# Cythère

Uni, jour échelle  
Plain dye pure linen, hemstitch



Made in France

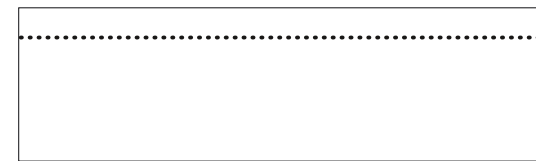

## DRAP

Drap uni  
Parement retourné de 15 cm,  
jour échelle

## FLAT SHEET

Plain dye  
6" border with hemstitch

## COULEURS / COLOURS



blanc  
white



naturel  
natural

Lin tissé et teint en **FRANCE**  
Linen woven and dyed in  
**FRANCE**

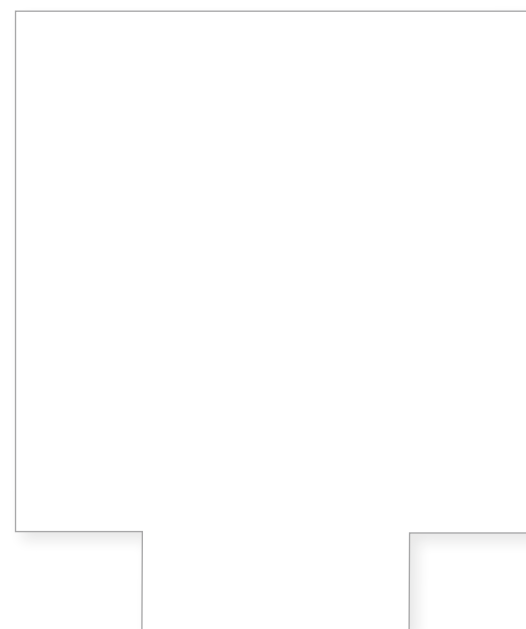

## HOUSSE DE COUETTE

Housse de couette unie

## DUVET COVER

Plain dye

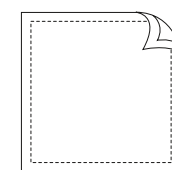

## TAIE

Taies unies  
volant de 6 cm, jour échelle

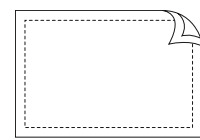

## PILLOWCASE

Plain dye  
2" flange with hemstitch

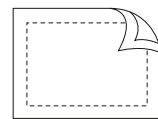

## TRAVERSIN

Parement de 6 cm, jour échelle

## BOLSTER

2" border, hemstitch

# Maine

Drap housse uni, 100% lin  
Plain dye pure linen fitted sheet



Made in France

## COULEURS / COLOURS



blanc  
white



naturel  
natural

Lin tissé et teint en **FRANCE**  
Linen woven and dyed in  
**FRANCE**

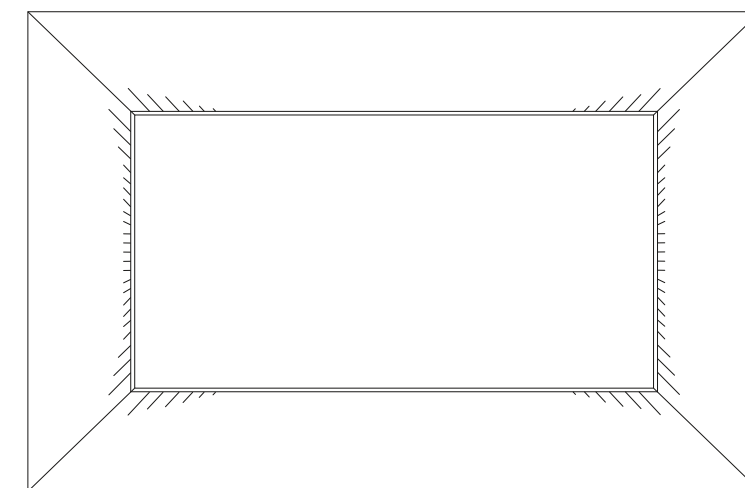

## DRAP HOUSSE

Profondeur de bonnet 30 cm

## FITTED SHEET

Pocket depth 12"



Bleu cascade  
waterfall blue

NOTRE LIN DURABLE  
TEILLÉ, TISSÉ, TEINT  
EN FRANCE

SUSTAINABLE LINEN  
HACKLINED, WOVEN AND  
DYED IN FRANCE

AFNOR Cert.83773

**ALEXANDRE TURPAULT** fait le choix d'un lin tissé et ennoblé en France, rincé à l'eau pure, sans aucun produit chimique, pour plus de douceur et un rendu plus souple. Un choix éthique pour prendre soin de vous aujourd'hui et demain.

#### • UNE PLANTE DURABLE

Une matière naturelle, issue d'une fibre végétale aux propriétés exceptionnelles (anallergique naturel, douce pour la peau, résistante). La culture du lin consomme très peu d'eau et nécessite très peu d'engrais.

#### • UNE PRODUCTION LOCALE : UN LIN TISSÉ ET ENNOBLI EN FRANCE

Un lin longue fibre, d'une couleur argentée issu d'une production agricole locale, tissé dans les Vosges puis ennoblé à quelques kilomètres de notre atelier dans les Hauts-de-France.

#### • UN CONFORT UNIQUE

Notre 100% lin est rincé à l'eau pure pour l'assouplir et lui donner un toucher naturellement plus doux pour une expérience sensorielle positivement luxueuse.

**ALEXANDRE TURPAULT** has chosen linen woven and finished in France, washed in pure water without any added chemicals, to make it softer and smoother. An ethical choice that cares for you, today and tomorrow:

#### • A SUSTAINABLE PLANT

A natural fabric, produced from vegetable fibres with exceptional properties (naturally hypoallergenic, soft on the skin, resistant). The cultivation of flax uses very little water and very little fertilizer.

#### • LOCALLY PRODUCED: OUR LINENS ARE WOVEN AND FINISHED IN FRANCE

Silver coloured, long-fibre linen, that is locally produced (Normandy, Artois and Flanders, woven in the Vosges and finished only a few kilometers from our workshop in the Hauts-de-France.

#### • UNIQUELY COMFORTABLE

Our 100% linen fabric is pre-washed in pure water to soften it and give it a naturally smooth feel, so you can enjoy a feeling of luxury every day.

## Nouvelle Vague

Lin uni «pré-lavé»  
Pre-washed 100% linen

Sienna  
Sienna

Made in France

#### ACCESSOIRES COORDONÉS / COORDINATED ACCESSORIES

Loulou  
hermine  
ermine

I'île aux oiseaux

Velin  
ivoire  
ivory

#### COULEURS / COLOURS





# Nouvelle Vague

Lin uni «pré-lavé»  
Pre-washed 100% linen



Natural  
Natural



boisé/pink beige  
et aube/pink dew

Made in France

## ACCESSOIRES COORDONNÉS / COORDINATED ACCESSORIES



Voltaire  
bruyère  
heather



Bloom  
boisé  
beige pink



Loulou  
rosée  
pink dew



Velin  
praline

NOTRE LIN DURABLE  
TEILLÉ, TISSÉ, TEINT  
EN FRANCE

SUSTAINABLE LINEN  
HACKLINED, WOVEN AND  
DYED IN FRANCE

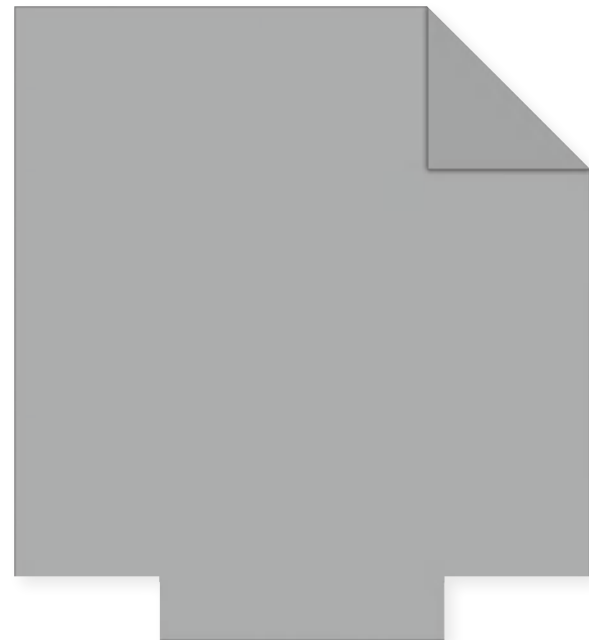

### HOUSSE DE COUETTE

Face et dos lin uni.

### DUVET COVER

Plain dye pure linen.

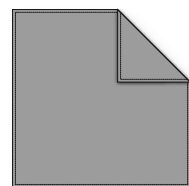

### TAIE

Face et dos lin uni,  
Taie volant piqué 1cm, simple rabat.

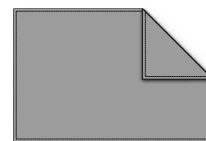

### PILLOWCASE

Plain dye pure linen,  
0,4 flange, simple flap.

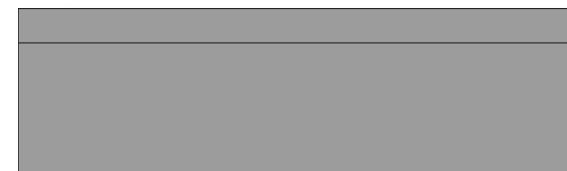

### DRAP

Corps uni, parement uni de 15cm.

### FLAT SHEET

Plain body, 6" plain dye border.

# Nouvelle Vague



Eucalyptus



Blanc / White

Made in France

## ACCESSOIRES COORDONNÉS / COORDINATED ACCESSORIES



Bloom  
eucalyptus



Loulou  
eucalyptus



Bloom  
or  
gold



Loulou  
hermine  
ermine

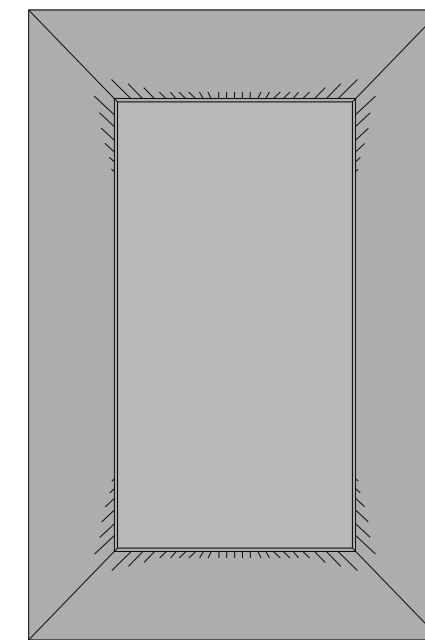

### DRAP HOUSSE

Corps uni,  
Profondeur de bonnet 30 cm.

### FITTED SHEET

Plain body,  
pocket depth 12".



# Bastide



Lin bicolore, double volant et galon décoratif  
Bleached linen, two-tone, double flange with decorative ribbon



Made in France

## ACCESSOIRES ET COULEURS / COORDINATED ACCESSORIES AND COLOURS



Loulou hermine  
ermine



blanc / naturel  
white / natural

Lin tissé et teint en FRANCE  
Linen woven and dyed in FRANCE

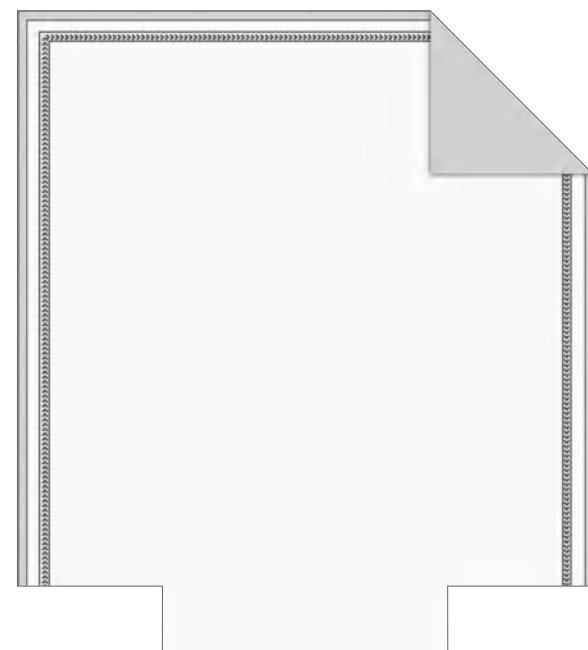

### HOUSSE DE COUETTE

Face : blanc / dos : naturel.  
double volant 10cm blanc dessus,  
naturel dessous sur 3 cotés galon  
décoratif appliqué sur 3 cotés

### DUVET COVER

Front : white / back : natural  
4" double flange , white on top,  
natural below, on 3 sides  
appliqué decorative ribbon on 3 sides

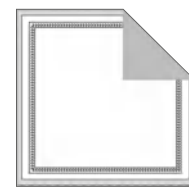

### TAIE

Face : blanc / dos : naturel  
double volant 7cm blanc dessus,  
naturel ou argent dessous  
galon décoratif appliqué

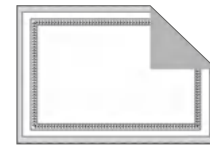

### PILLOWCASE

Front : white / back : natural.  
2.75" double flange,  
white on top,natural below  
appliqué decorative ribbon



### DRAP

Corps blanc  
double volant de 15cm  
galon décoratif appliqué

### FLAT SHEET

White body  
4"double flange  
appliqué decorative ribbon

# Keops

Lin uni, jour « Venise » (Fabrication sur commande)  
Plain dye, pure linen, « Venetian » lace  
(production on special order)



Made in France

## ACCESSOIRES ET UNIS COORDONNÉS / COORDINATED ACCESSORIES AND COLOURS



Loulou hermine  
ermine



Maine blanc  
Maine white

Lin tissé, brodé et teint  
en FRANCE  
Linen woven, embroidered  
and dyed in FRANCE

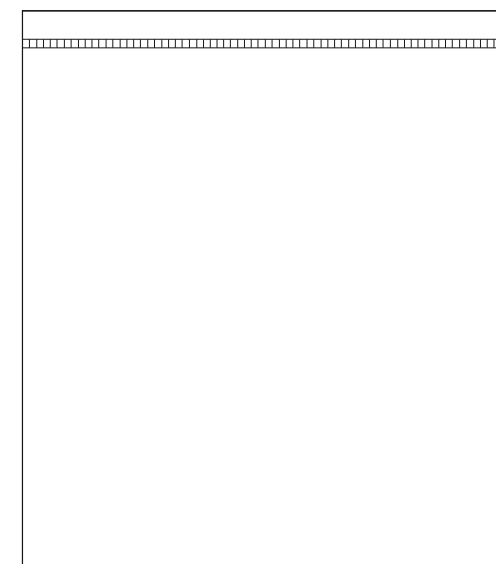

### DRAP

Parement retourné à 10 cm ,  
jour " Venise "

### FLAT SHEET

4" border, « Venetian » lace

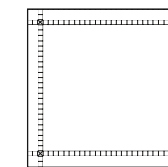

### TAIE

Parements de 6 cm ,  
jour " Venise ",  
coins ouverts

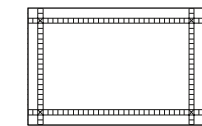

### PILLOWCASE

2" flange, « Venetian » lace,  
open corners

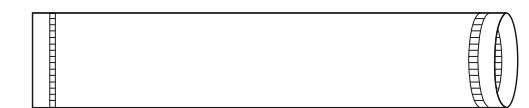
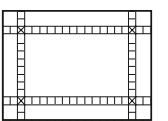

### TRAVERSIN

Parements de 6 cm , jour " Venise "

### BOLSTER

2" border, « Venetian » lace





## Le jour Venise

Le jour Venise est une broderie représentant une ouverture décorative pratiquée dans l'étoffe. L'ensemble de ces ouvertures apparaît comme une succession de petits rectangles mettant en valeur le bord de l'étoffe, notamment d'un drap ou le volant d'une taie d'oreiller. Afin de les confectionner, les ateliers procèdent par cinq étapes, issues du savoir-faire français depuis 1847.

The «Venitian» lace can be described as an embroidery technique creating decorative opertures in the fabric. Also called ladder stitch, this particular pattern features lignes of small rectangular holes. A traditional ornament is used to enhance bedlinen sheets or pillowcase. The manufacturing of «Venitian» lace takes five steps. This very specific know how is part of the company DNA since 1847.

### COUPE À LA MAIN

### TIRAGE DE FILS

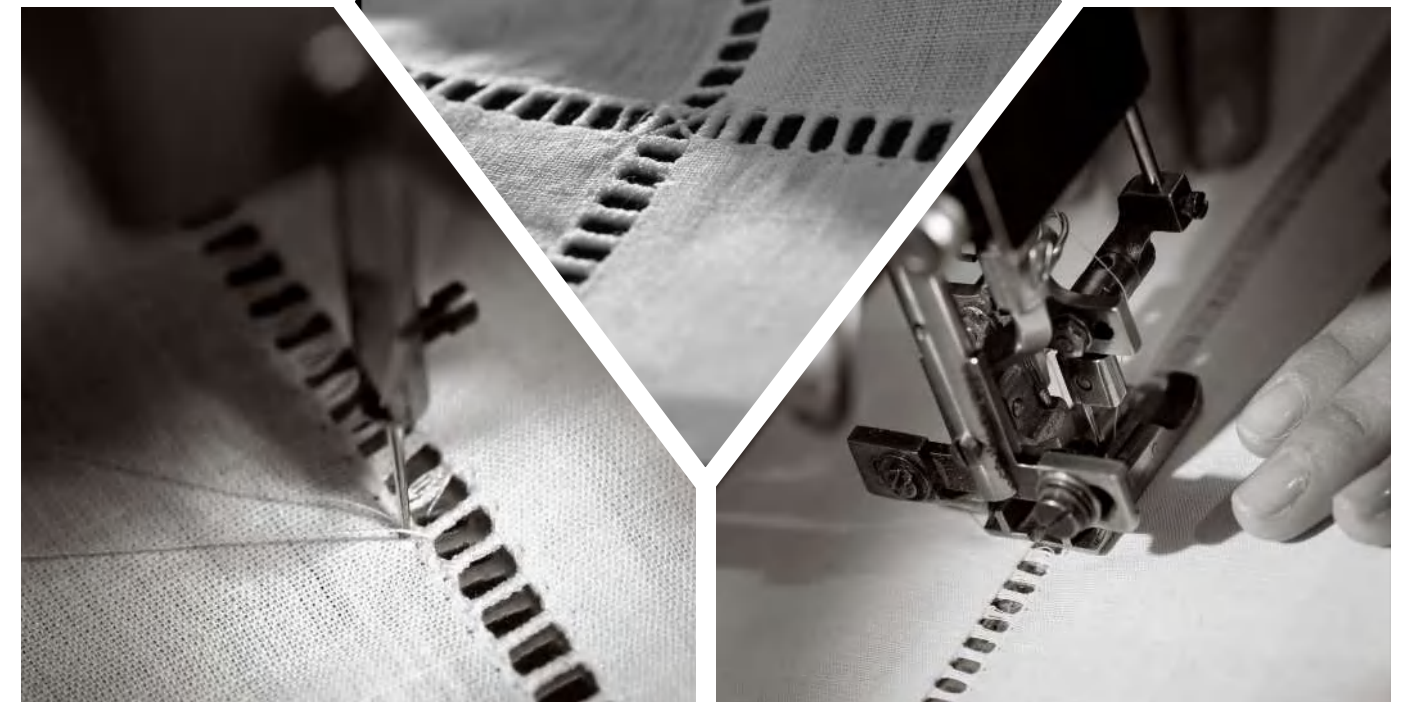
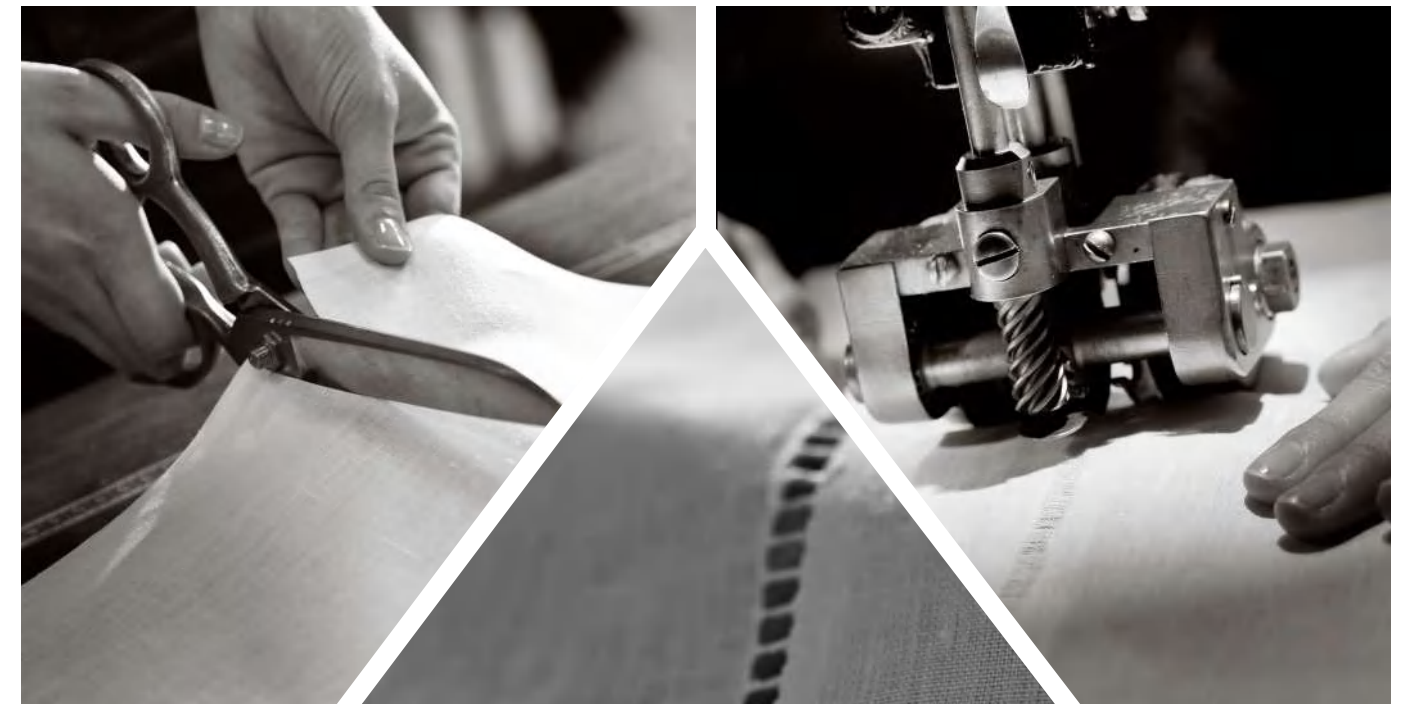

### UNIS COORDONNÉS / COORDINATED COLOURS

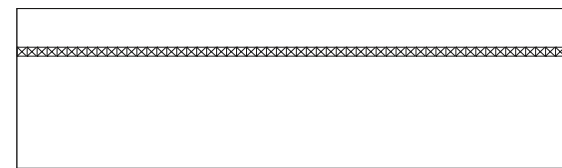

#### DRAP

Parement retourné à 10 cm ,  
jour « Venise » croisé

#### FLAT SHEET

4" border,  
Crossed « Venetian » lace



Maine blanc  
Maine white

Lin tissé, brodé et teint  
en FRANCE  
Linen woven, embroidered  
and dyed in FRANCE

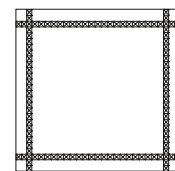

#### TAIE

Parements de 6 cm ,  
Jour « Venise » croisé,  
coins ouverts

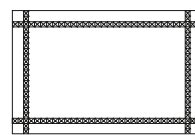

#### PILLOWCASE

2" flange,  
Crossed « Venetian » lace  
open corners

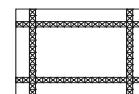

#### HOUSSE DE COUETTE

Parement de 30 cm ,  
jour « Venise » croisé

#### DUVET COVER

12" border,  
crossed « Venetian » lace

#### TRAVERSIN

Parements de 6 cm ,  
jour « Venise » croisé

#### BOLSTER

2" border,  
Crossed « Venetian » lace

### BRODERIE DES BARRETTES

### AJOURAGE



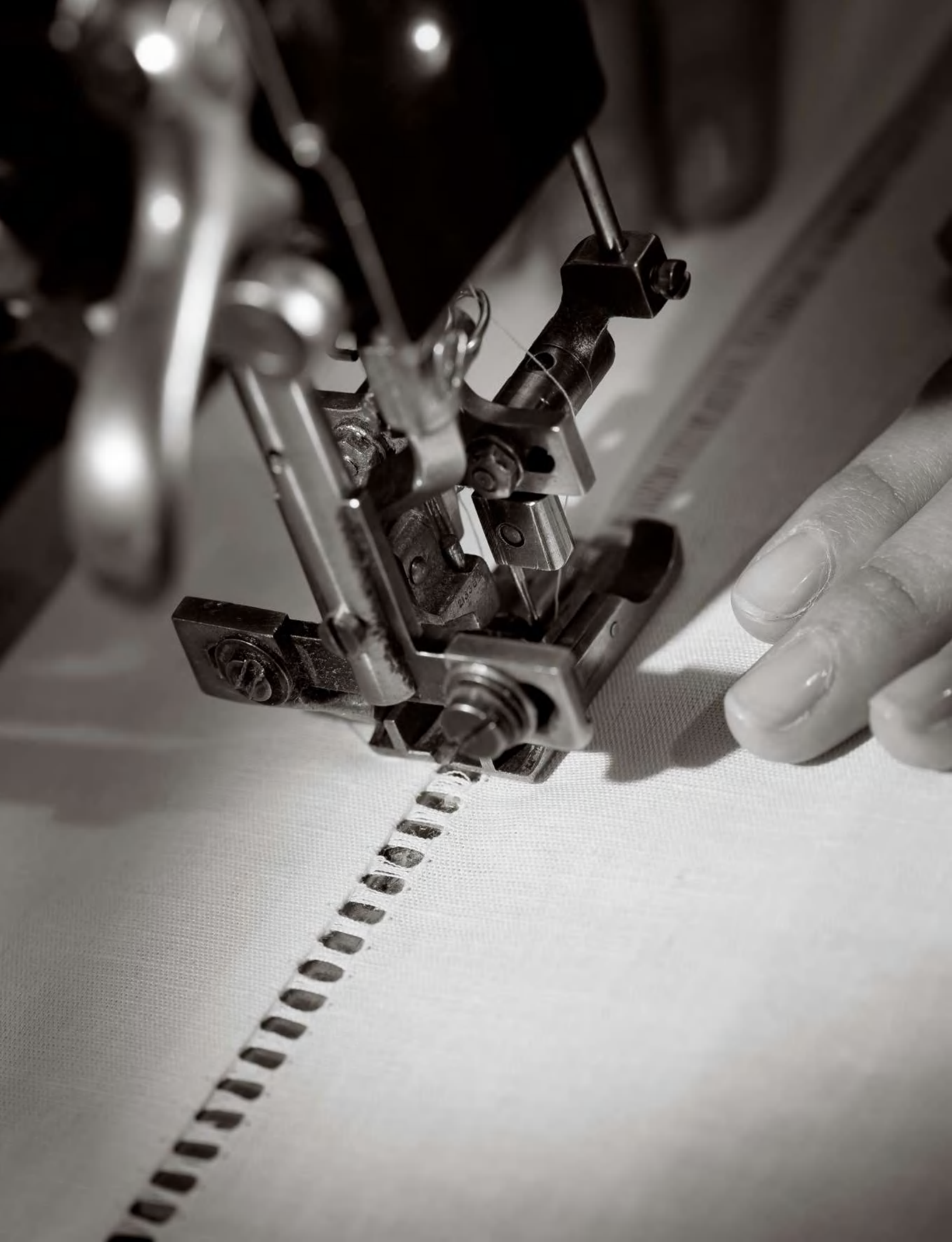

# ALEXANDRE TURPAULT

FRANCE 1847

## Lit métis

**Alexandre Turpault** vous présente sa collection de linge de lit Métis.

Spécialiste du lin depuis 1847, **Alexandre Turpault** associe le lin et coton

Lin tissé et ennobli en France.

Tissage alliant les qualités du lin et du coton : au moins 48% lin.

Pur lin longues fibres.

Fibres naturelles, toucher agréable et facile d'entretien.

Finition « jour échelle » ou « jour Venise » pour le raffinement du beau linge.

## Halflinen bedlinen

**Alexandre Turpault** presents its cotton and linen bed linen collection.

Specialising in linen since 1847, **Alexandre Turpault** combines linen and cotton

High quality, Linen woven in France.

Weaving combining the qualities of linen and cotton: at least 48% linen.

Pure linen with long fibers.

Natural fibre, pleasant feel for daily use.

« Hemstich » or « Venitian lace » finishes for elegant fine linen.

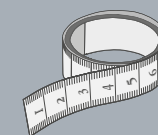

Service sur mesure : dimensions spéciales sur tarif ou sur simple demande.

Custom size service : quotation available on price list or upon request.

Cachou  
Ontario

46 Paris  
46 Venise

47  
48



# Cachou

Cache-sommier métis uni à rubans  
Plain dye half linen bedskirt with ribbons



Made in France

# Ontario

Drap housse uni metis  
Plain dye half linen fitted sheet



Made in France

# Paris

Bicolore, finition jour « Venise »  
Two-tone, half linen with « Venetian » lace



Made in France

## COULEURS / COLOURS

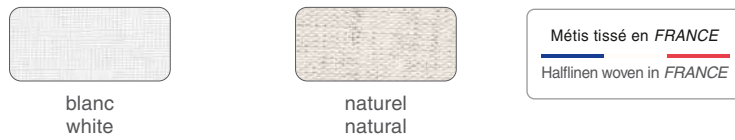

## COULEURS / COLOURS



## UNIS COORDONNÉS / COORDINATED COLOURS

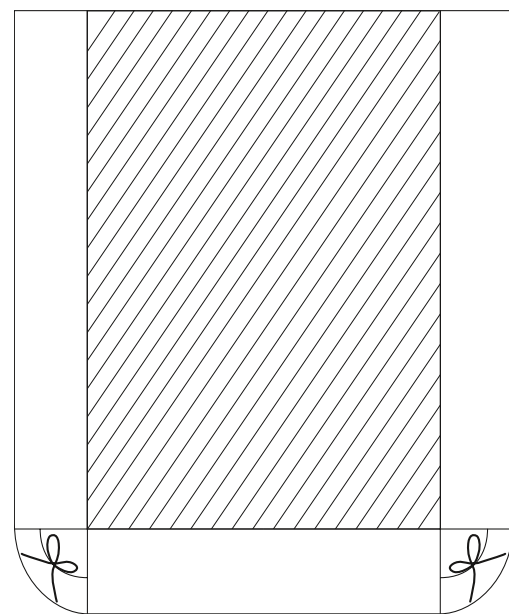

### CACHE-SOMMIER

3 côtés en métis, hauteur de 28 cm, plateau pur coton, angles fermés par un ruban

### BEDSKIRT

3 sides in half linen, 11" drop, deck in pure cotton, Corners tied by half linen ribbons

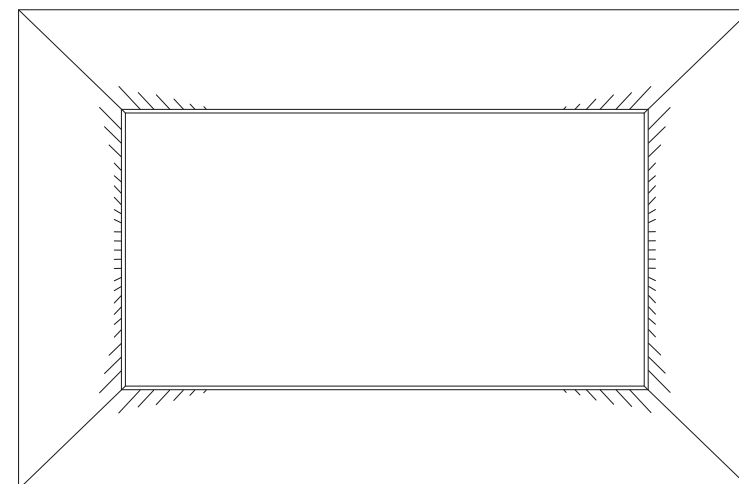

### DRAP HOUSSE

Profondeur de bonnet de 30 cm, élastiques tête et pieds

### FITTED SHEET

Pocket depth 12" elastic on top and bottom



### TRAVERSIN

Parement de 15 cm avec Jour « Venise »

### FLAT SHEET

6" border with « Venetian » lace

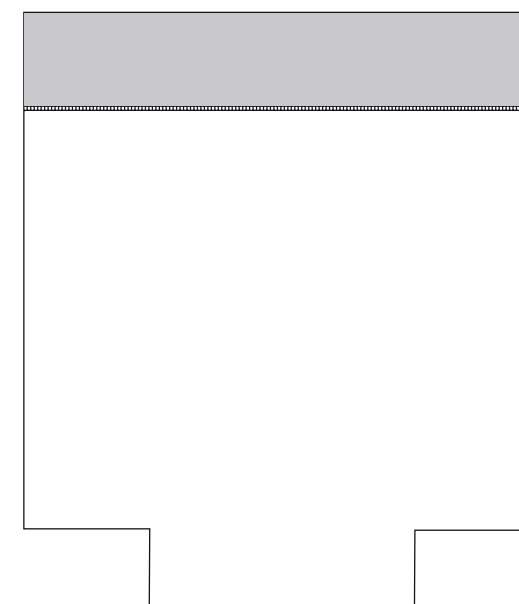

### HOUSSE DE COUETTE

Parement contrasté de 40 cm, jour « Venise »

### DUVET COVER

16" contrasting border « Venetian » lace

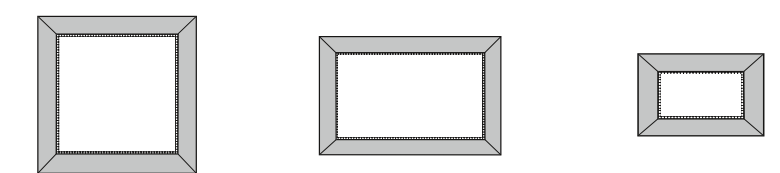

### TAIE

Parements appliqués de 7 cm, Coins capuchons, jour « Venise »

### PILLOWCASE

3" contrasting flange, mitred corner, « Venetian » lace

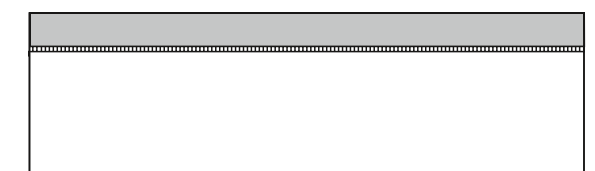

### DRAP

Parement contrasté à 10 cm, Jour « Venise »

### FLAT SHEET

4" contrasting border, « Venetian » lace



# Venise

Uni, finition jour « Venise »  
Plain dye, halfinen with « Venetian » lace



Made in France

## COULEURS / COLOURS

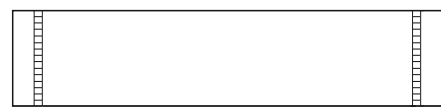

### TRAVERSIN

Parements de 7 cm , jour « Venise »

### FLAT SHEET

3" border, « Venetian » lace



blanc  
white



naturel  
natural

Métis tissé en FRANCE  
Halfinen woven in FRANCE

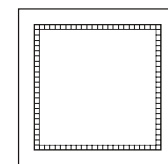

### TAIE

Parements de 7 cm ,  
jour « Venise »

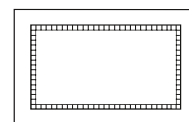

### PILLOWCASE

3" flange, « Venetian » lace

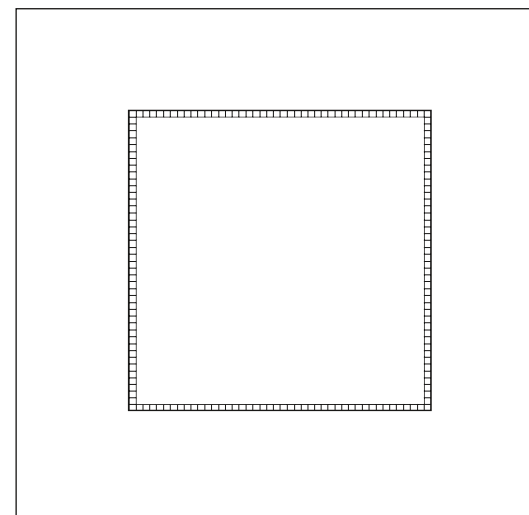
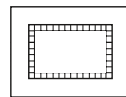

### HOUSSE DE COUETTE

Encadré Jour « Venise » à 40 cm  
des bords

### DUVET COVER

« Venetian » lace frame  
placed at 16" from edges

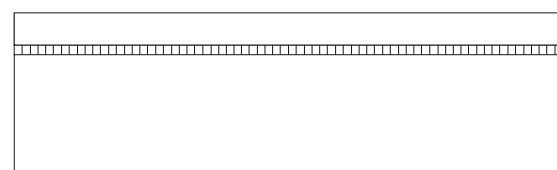

### DRAP

Parement de 7 cm , jour « Venise »

### FLAT SHEET

3" border, « Venetian » lace

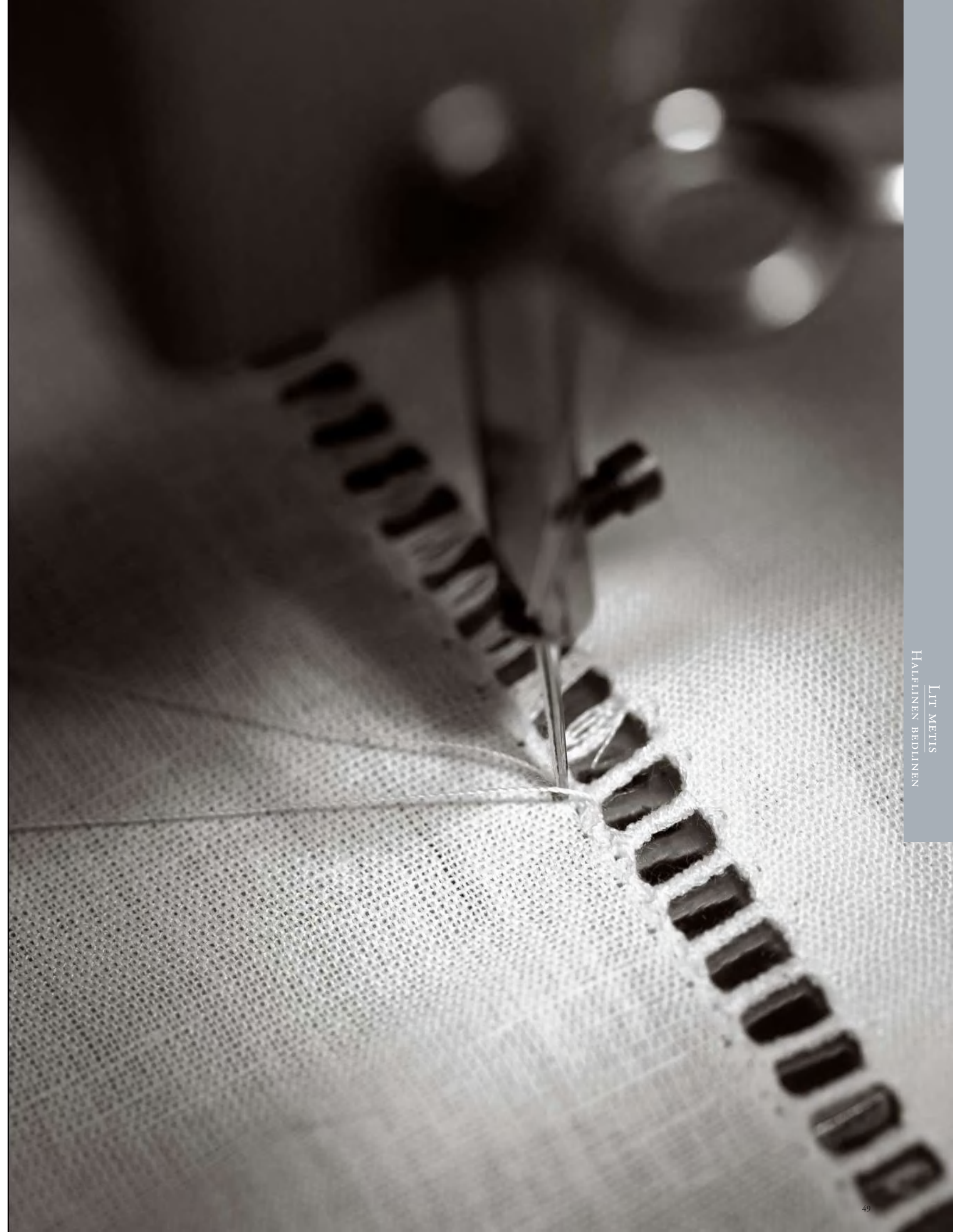





# ALEXANDRE TURPAULT

FRANCE 1847

## Accessoires Accessories

**Alexandre Turpault** vous propose une gamme d'accessoires issue d'une recherche éthique et esthétique.

Pour parfaire l'univers du linge de lit, nous utilisons des matières nobles qui vous apporteront pleine satisfaction par la qualité de leur provenance, de leur douceur et de leur finition.

- du baby alpaga en Provenance du Pérou,
- de la fausse fourrure d'une extrême douceur telle une vraie fourrure,
- du lin Européen imprimé,
- du satin de coton 120 fils longues fibres.

**Alexandre Turpault** offers you a range of accessories which are the result of ethical and esthetic research.

To complete the bed linen collection, we use natural materials which will give you complete satisfaction with the quality of their material, their softness and finish.

- baby alpaca from Peru,
- extremely soft faux fur for throws, bedcovers and cushions,
- European printed pure linen,
- 300TC/inch cotton sateen with an exceptional fibre quality.

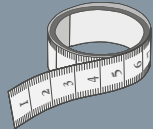

Service sur mesure : dimensions spéciales sur tarif ou sur simple demande.  
Custom size service : quotation available on price list or upon request.

Bel Oiseau	56	<b>Poesie</b> <sup>NEW</sup>	64
Bloom	57	Tsarine	66
Estampe	58	Ashlyn	67
<b>L'île aux oiseaux</b> <sup>NEW</sup>	59	Velin	67
Loulou	60	Voltaire	68
Nomade	61		
Merveille	62		



# Bel Oiseau

Housse de coussin en tapisserie "L'envol de la grue cendrée"  
"The flying crane" tapestry cushion case



Made in France

## COULEURS / COLOURS

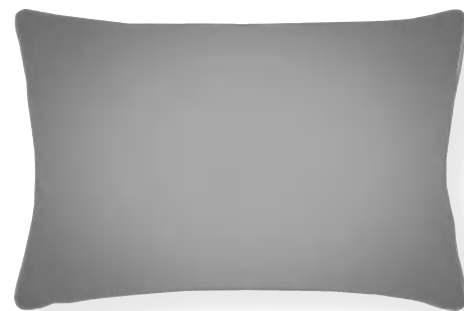

40x60 cm  
15,5 x23,5"

### HOUSSE DE COUSSIN

Tapiserie motif placé "L'envol de la grue cendrée", dos en 100% lin uni, passepoil lin naturel, fermeture à glissière. Composition tapisserie 65% coton 4% polyester 31% viscose.

### CUSHION CASE

"The flying crane" engineered design tapestry reversing to plain dye 100% linen, natural linen piping, zip fastening. Tapestry material 65% cotton 4% polyester 31% viscose.

# Bloom

Housse de coussin et courtepointe en lin imprimé "Bloom"  
"Bloom" printed linen cushion case and small bed cover



Made in France

## COULEURS / COLOURS



eucalyptus  
eucalyptus



boisé  
beige pink



or  
gold

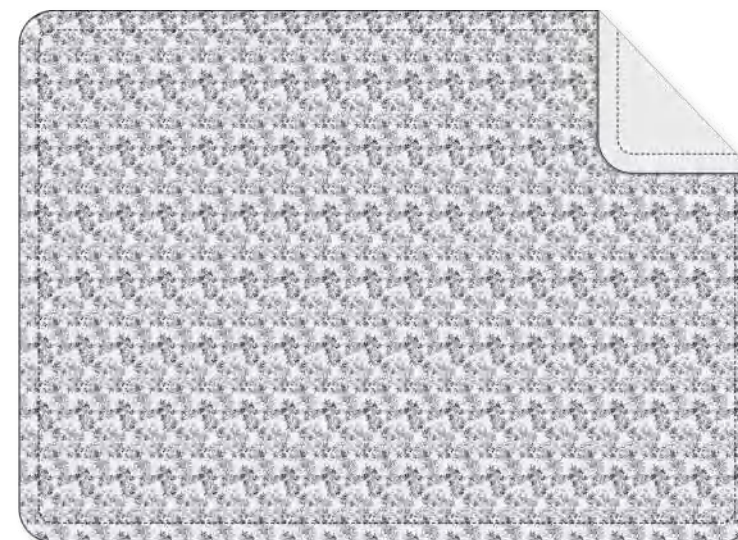

130x180cm  
51x71"

### COURTEPOINTE

Face imprimée "Bloom", dos lin uni naturel, intérieur ouate de polyester 150g/m<sup>2</sup>

### COUNTERPANE

"Bloom" printed linen reversing to undyed linen natural, polyester wade inside 150g/m



30x40cm  
11.8x15.5"    40x60 cm  
15,5 x23,5"

### HOUSSE DE COUSSIN

Lin imprimé "Bloom", 2 faces identiques, passepoil naturel, fermeture à glissière.

### CUSHION CASE

"Bloom" printed linen on both sides, natural piping, zip fastening.



# Estampe

Housse de coussin en 100% lin imprimé "Couple de grue cendrées"  
"Couple of cranes" 100% linen printed cushion case



## COULEURS / COLOURS



40x60cm | 15.5x23.5"

### HOUSSE DE COUSSIN

Housse de coussin 100% lin réversible, face imprimée motif placé "Couple de grues cendrées", dos imprimé motif placé "l'envol", passepoil contrasté, fermeture à glissière.

### CUSHION CASE

100% linen printed cushion case, on face engineered design "Couple of cranes" reversing to engineered design "Flying", contrasting piping, zip fastening.

# L'île aux oiseaux

Housse de coussin en 100% lin imprimé "L'île aux oiseaux"  
"Birds island" 100% linen printed cushion case

NEW



## COULEURS / COLOURS

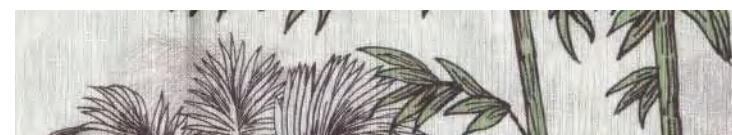

40x60cm | 15.5x23.5"

### HOUSSE DE COUSSIN

Housse de coussin 100% lin réversible, face imprimée motif placé "Oiseau de paradis", dos imprimé motif placé "colibri", passepoil contrasté, fermeture à glissière.

### CUSHION CASE

100% linen printed cushion case, on face engineered design "paradise bird" reversing to engineered design "colibri bird", contrasting piping, zip fastening.



# Loulou



Plaid tissé teint laine/soie/cashemire  
Yarn dyed throw, wool/silk/cashmere



Made in Italy

# Nomade



Plaid en baby alpaga, motif "effet de tissage"  
Baby Alpaca throw, "weaving effect"



Made in Peru

## COULEURS / COLOURS



Latte



beige



gris  
grey



hermine  
ermine



rosée  
pink/dew



eucalyptus

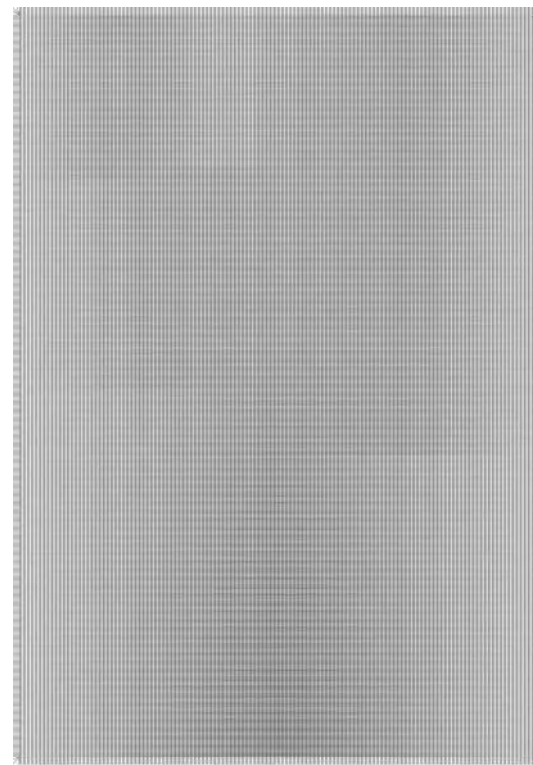

140 x 200 cm  
55 x 79"

### PLAID

Plaid tissé teint laine/soie/cashemire,  
franges 2cm.  
70% laine / 20% soie / 10%  
cashemire

### THROW

Yarn dyed throw, wool/silk/cashmere,  
0.8" fringes  
70% wool / 20% silk / 10% cashmere

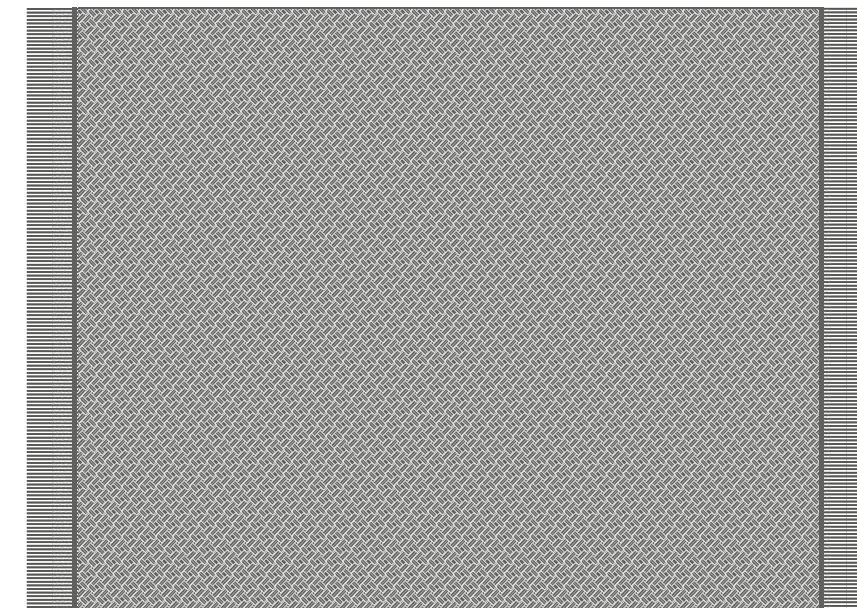

### PLAID

100% Baby Alpaca,  
motif "effet de tressage", bicolore non  
teint, bordé de franges de 10cm  
130x180cm, 645g/m<sup>2</sup>

### THROW

100% Baby Alpaca,  
two tone natural colour "weaving  
effect" pattern,  
51x71", 645g/m<sup>2</sup>



# Merveille

Couvre-lit en satin de coton matelassé bicolore réversible à motif "grands carreaux à double piqûre"  
 Reversible two tones quilted cotton sateen bed cover, "large double stitched squares" pattern



zibeline / nacre  
 sable / oyster

Made in Italy



gazelle / hermine  
 ermine / gazelle

## COULEURS / COLOURS

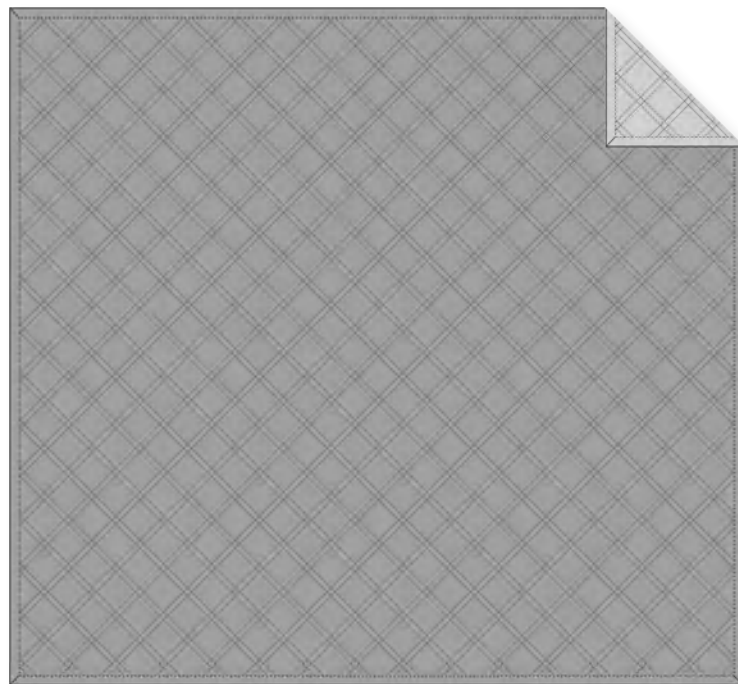

désert / lune  
 désert beige / moon beige



zibeline / nacre  
 sable / oyster

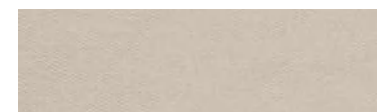

gazelle / hermine  
 gazelle / ermine

### COUVRE LIT

Satin de coton piqué réversible bicolore. Parement de 3cm, coins capuchons. Garnissage ouate de polyester 100g. Dimension : 260x240 et 280x240cm et disponible en Sur-mesure.

### BEDCOVER

Two tone reversible quilted cotton sateen. 1.2" border, mitred corner. 100g polyester wad filling. Dimension: 102x95" and 110x102" and made to measure service available.



MERVEILLE désert/lune présenté sur le revers.  
 Presentation of MERVEILLE desert beige/moon beige on the reverse.

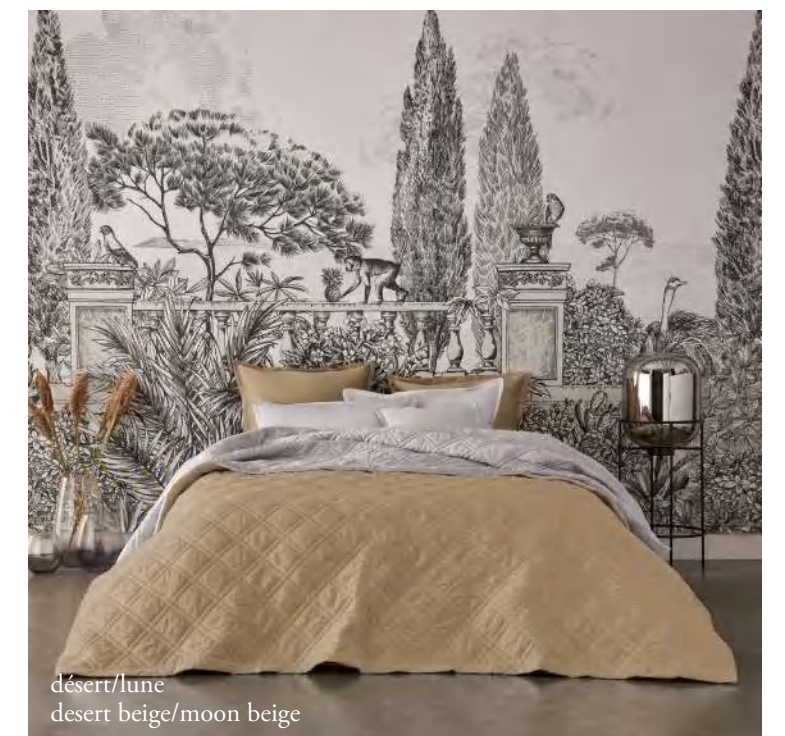

désert/lune  
 desert beige/moon beige



# Poesie

Uni matelassé motif "tressage" en satin de coton  
Quilted "knitting" pattern, cotton sateen

NEW



marine / slate blue

Made in Italy



rosé / pink dew









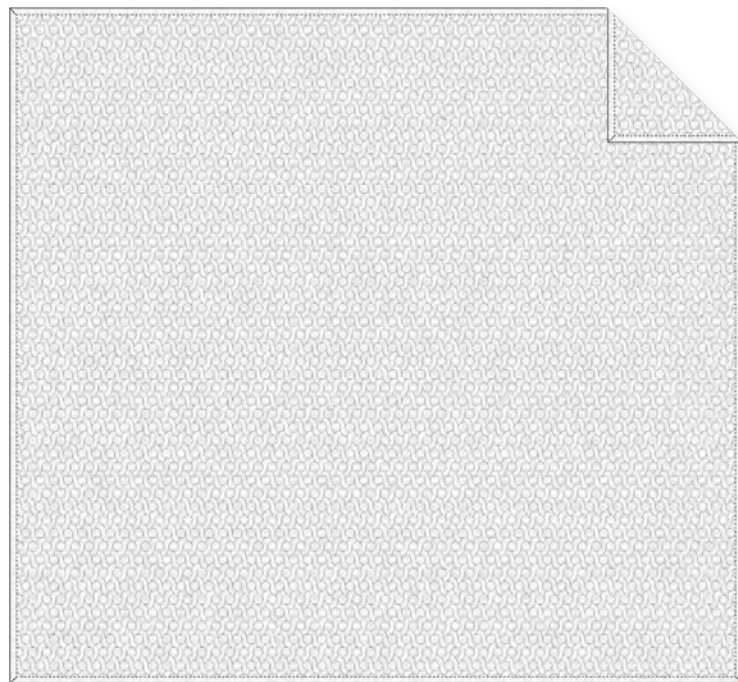

or / gold



baltique / baltic blue

## COULEURS / COLOURS



	
baltique baltic blue	Neige Snow white
	
éclipse almost black	Argent Silver grey
	
or gold	Marine Slate blue
	
rosée pink dew	

NEW

NEW

NEW

### COUVRE LIT

Satin de coton piqué uni,  
parement de 2,5cm coins capuchons  
garnissage ouate polyester 100gr/m<sup>2</sup>  
260x240cm  
Produit disponible en sur mesure  
(voir tarif)

### BEDCOVER

Quilted plain dye sateen,  
1" border plain dye sateen, mitred corner,  
100gr/m<sup>2</sup> polyester wad filling  
102x95"  
Custom made service available  
(check your pricelist)



# Tsarine

Housse de coussin et couvre-lit fausse fourrure  
Cushion case and throw made of synthetic faux-fur



Confectionné en France

# Ashlyn

(caspule upcycling  
en édition limitée -  
Limited edition)



Made in Italy

Housse de coussin jacquard lin et soie  
Linen & silk jacquard cushion case

# Velin

(caspule upcycling  
en édition limitée -  
Limited edition)



Made in France.

Housse de coussin en velours de coton uni et  
lin naturel.  
Plain dye cotton velvet and natural linen  
cushion case.



## COULEURS / COLOURS



zibeline / sable \*



50x50cm  
18"x18"

### PLAID ET COUVRE LIT

Face: fourrure synthétique,  
68% acrylique, 15%  
polyester, 17% modacrylique  
dos : 100% satin de coton.

### THROW AND BEDCOVER

Front : synthetic faux-fur  
68% acrylique, 15%  
polyester, 17% modacrylique  
back : 100% cotton sateen.

### HOUSSE DE COUSSIN

Face: fourrure synthétique 68%  
acrylique, 15% polyester, 17%  
modacrylique  
dos: 100% satin de coton passepoil  
fermeture à glissière

### CUSHION CASE

Front: synthetic faux-fur  
68% acrylique, 15% polyester, 17%  
modacrylique  
back : 100% cotton sateen  
zip

## COULEURS / COLOURS



naturel  
natural



caspule upcycling  
en édition limitée -  
Limited edition



### CUSHION CASE

Front in linen & silk jacquard "leaves" pattern, reversing to linen simple weave.  
Serpentine ribbon piping, zip fastening.

## COULEURS / COLOURS



ivoire  
ivory

praline  
praline

rouille  
rust



40x60cm  
15.5x23.5"

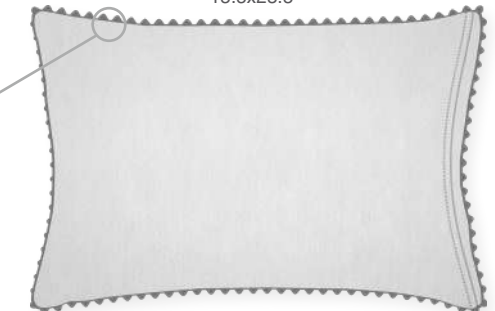

### HOUSSE DE COUSSIN

Face velours de coton uni, dos  
lin naturel, ruban Serpentine en  
passepoil, simple rabat au dos.

### CUSHION CASE

Plain dye cotton velvet, reversing  
to undyed natural linen, Serpentine  
ribbon piping, simple flap in the back.



# Voltaire

Housse de coussin en lin et chenille velours tissé teint  
Yarn dyed chenille velvet and linen Cushion case



Made in Belgium

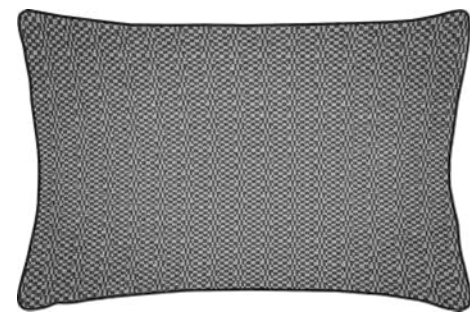

40x60cm  
15.5x23.5"

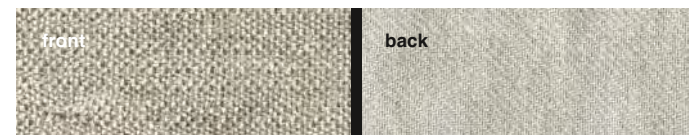
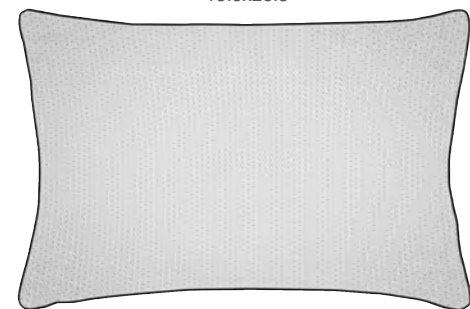

nuage/silver  
cloud

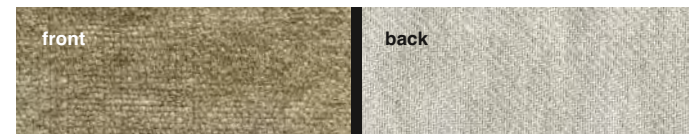

jonc/antic  
gold

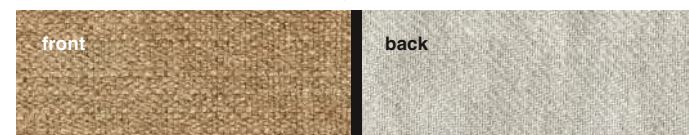

chanterelle

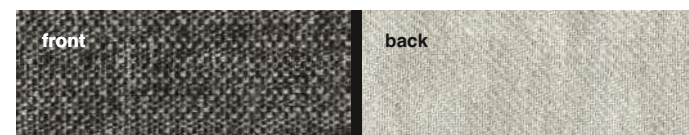

tourbe  
peat black

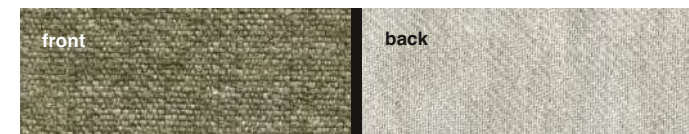

lichen  
moss green

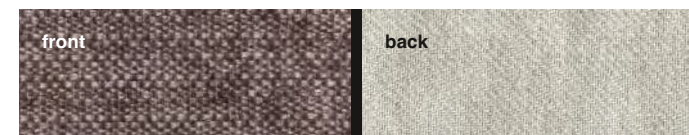

bruyère  
heather

## HOUSSE DE COUSSIN

Face velours 55% lin - 9% coton - 7% polyester - 29% viscose. Dos sergé 100% lin. Passepoil contrasté. Fermeture à glissière.

## CUSHION CASE

Front in velvet 55% lin - 9% coton - 7% polyester - 29% viscose. Back in 100% linen twill. Contrasting piping. Zip fastening.







Draps de plage Succulente et Belize

« Textile biologique. Certificat délivré par Ecocert Greenlife selon le référentiel GOTS consultable sur <http://www.ecocert.com> »

Organic. Certificate delivered by Ecocert Greenlife according to the GOTS Standard available on <http://www.ecocert.com>.



# ALEXANDRE TURPAULT

FRANCE 1847

## Linge de toilette

100% COTON ISSU DE L'AGRICULTURE  
BIOLOGIQUE

**Alexandre Turpault** vous présente sa collection de linge de toilette.

serviettes, serviettes d'invité, carrés visages, gants, draps de douche, draps de bain, peignoirs et tapis de bain pour une gamme complète

650gr/m<sup>2</sup> pour les serviettes, 400gr/m<sup>2</sup> pour les peignoirs et 1200gr/m<sup>2</sup> pour les tapis de bain pour plus de douceur et de gonflant

peignoirs fantaisies en velours jacquard ou en tissage plat.

La gamme linge de bain Alexandre Turpault est 100% en coton peigné issu de l'agriculture biologique.\*

Le niveau de labellisation « textile biologique » du standard GOTS garantit que le produit contient 95% de fibre biologique et que les critères sociaux définis par les conventions de l'Organisation internationale du travail (OIT) sont respectés (droits des salariés, liberté syndicale, pas de travail des enfants, pas de travail forcé, sécurité du travail, salaires décents, etc.)

## Bathlinen

100% ORGANICALLY GROWN COTTON

**Alexandre Turpault** presents its bathroom collection.

towels, guest towels, face cloth, wash glove, shower towel, bath sheet, bathrobes and bath mats for a complete range

650 gr/m<sup>2</sup> for towels, 400 gr/m<sup>2</sup> for bathrobes and 1200gr/m<sup>2</sup> for bath mat for greater softness and pile

bathrobes in velvet jacquard or herringbone pattern weave

A unique plain dye Organic cotton bath linen.\*

The label grade « organic » of GOTS standard guarantees that the product contains 95% of organic fibers certified and that the social criteria defined by the International Labour Organisation (ILO) conventions (employee rights, freedom of association, no child labour, no forced labour, safety at work, decent wages, etc.) are respected.

Essentiel  
Ess-cadre  
Ess-calle  
Ess-kimo

68  
69  
70  
70

**Belize**<sup>NEW</sup>  
**Succulente**<sup>NEW</sup>

72  
73



# Essentiel



ombre / taupe

Made in Portugal

Uni coton peigné, biologique, liteau armuré  
Plain dye organic combed cotton terry with fancy weave border



bleu islande  
island blue

Made in Portugal

# Ess-cadre



graphite / graphite grey

Made in Portugal

Uni coton peigné, biologique, liteau armuré  
Plain dye organic combed cotton terry with fancy weave border

## COULEURS / COLOURS

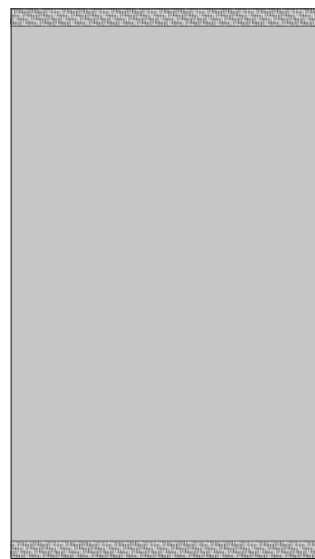

SERVIETTE

30 x 30 le Carré  
40 x 60 cm Serviette invité  
60 x 100 cm Serviette de toilette  
70 x 140 cm Drap de douche  
100 x 160 cm Drap de bain

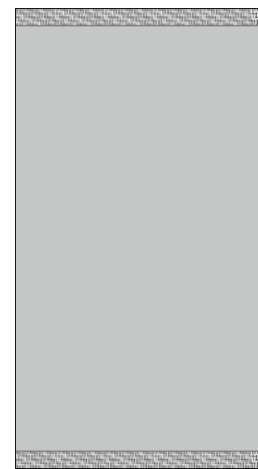

GUEST TOWEL

11,8 x 11,8" Face cloth  
16 x 24" Guest towel  
24 x 39" Hand towel  
28 x 55" Shower towel  
39 x 63" Bath sheet

« Textile biologique. Certificat délivré par Ecocert Greenlife selon le référentiel GOTS consultable sur <http://www.ecocert.com>. »

Organic. Certificate delivered by Ecocert Greenlife according to the GOTS Standard available on <http://www.ecocert.com>.



Organic  
Certified by Ecocert Greenlife  
Licence N° 123840

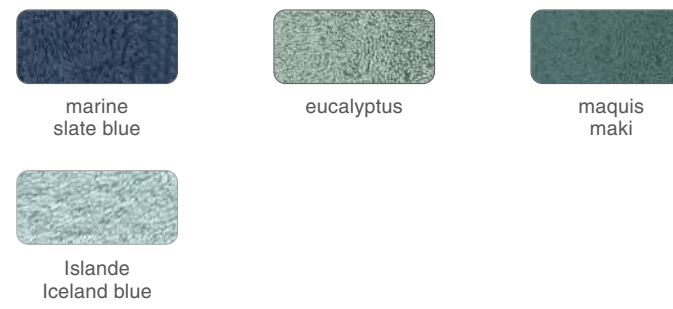

Islande  
Iceland blue

« Textile biologique. Certificat délivré par Ecocert Greenlife selon le référentiel GOTS consultable sur <http://www.ecocert.com>. »

Organic. Certificate delivered by Ecocert Greenlife according to the GOTS Standard available on <http://www.ecocert.com>.



Organic  
Certified by Ecocert Greenlife  
Licence N° 123840

GANT DE TOILETTE

16 x 21 cm / 650 gr/m<sup>2</sup>,  
En haut : liteau armuré de 1,5 cm

WASH GLOVE

6,4 x 8,4" / 650 gr/m<sup>2</sup>,  
In the top : 0,6" fancy weave border



ombre  
taupe

« Textile biologique. Certificat délivré par Ecocert Greenlife selon le référentiel GOTS consultable sur <http://www.ecocert.com>. »

Organic. Certificate delivered by Ecocert Greenlife according to the GOTS Standard available on <http://www.ecocert.com>.



Organic  
Certified by Ecocert Greenlife  
Licence N° 123840



ESS-CADRE

TAPIS DE BAIN\*

TAPIS DE BAIN  
60x90cm / 1200g/m<sup>2</sup>  
Double encadré  
Liteau simple de 2cm coté

BATH MAT\*

23,5 x 35,5 / 1200g/m<sup>2</sup>  
Double frame  
1,8" Simple hem



# Ess-cale



Uni coton peigné, biologique, col châle  
Plain dye organic combed cotton terry,  
shawl collar

« Textile biologique. Certificat délivré par Ecocert Greenlife selon le référentiel GOTS consultable sur <http://www.ecocert.com> »

Organic. Certificate delivered by Ecocert Greenlife according to the GOTS Standard available on <http://www.ecocert.com>.



Organic  
Certified by Ecocert Greenlife  
Licence N° 123840

## PEIGNOIR

S, M, L carrare, gazelle  
S,M,L, XL blanc  
400gr/m<sup>2</sup>

Corps et manches en éponge unie Biologique.  
Col châle

Passepoil coton encolure et manches  
Poignets de 7cm  
Ceinture de 5cm  
2 poches côtés invisibles  
Passants sur les côtés

## BATH ROBE

S, M, L light grey, gazelle  
S,M,L, XL white  
400gr/m<sup>2</sup>

Body and sleeves in Organic plain dye terry  
Shawl collar

Cotton piping at the collar and the cuff  
2,8" cuff  
2" belt  
2 invisible side pockets  
On the sides keeper

## COULEURS / COLOURS



blanc  
white



carrare  
light grey



gazelle  
gazelle

# Ess-kimo



Uni coton peigné, biologique, litem armuré  
Plain dye organic combed cotton terry with fancy  
weave border

« Textile biologique. Certificat délivré par Ecocert Greenlife selon le référentiel GOTS consultable sur <http://www.ecocert.com> »

Organic. Certificate delivered by Ecocert Greenlife according to the GOTS Standard available on <http://www.ecocert.com>.



Organic  
Certified by Ecocert Greenlife  
Licence N° 123840

## PEIGNOIR

S,M,L, XL blanc  
M, L, XL graphite, marine  
400gr/m<sup>2</sup>

Corps et manches en éponge unie Biologique.

Dans le litem armuré :  
Parement de 6cm  
Poignets de 6cm  
Ceinture de 5cm  
2 poches plaquées  
Passants sur les côtés

## BATH ROBE

S,M,L,XL white  
M, L, XL graphite grey, slate blue  
400gr/m<sup>2</sup>

Body and sleeves in Organic plain dye terry  
Details with fancy weave

2,4" collar  
2,4" cuff  
2" belt  
2 patch pockets  
On the sides keeper

## COULEURS / COLOURS



blanc  
white



graphite  
graphite grey



marine  
slate blue





# Belize

NEW



Made in Portugal

Draps de plage en jacquard velours, coton biologique  
Beach towel in velvet jacquard organic cotton



## DRAPS DE PLAGE

100x180 cm  
Drap de plage bicolore jacquard  
velours 500g/m<sup>2</sup> liteau fantaisie

## BEACH TOWELS

39,4x71"  
two tone velvet jacquard  
organic cotton 500gr/m<sup>2</sup>  
fancy border

« Textile biologique.  
Certificat délivré par  
Ecocert Greenlife selon  
le référentiel GOTS  
consultable sur  
<http://www.ecocert.com> »



Organic  
Certified by Ecocert Greenlife  
Licence N° 123840

Organic. Certificate  
delivered by Ecocert  
Greenlife according to  
the GOTS Standard  
available on  
<http://www.ecocert.com>.

# Succulente

NEW



Made in Portugal

Draps de plage en jacquard velours, coton biologique  
Beach towel in velvet jacquard organic cotton



kaki / khaki

## DRAPS DE PLAGE

100x180 cm  
Drap de plage bicolore jacquard  
velours 500g/m<sup>2</sup> liteau fantaisie

## BEACH TOWELS

39,4x71"  
two tone velvet jacquard  
organic cotton 500gr/m<sup>2</sup>  
fancy border

« Textile biologique.  
Certificat délivré par  
Ecocert Greenlife selon  
le référentiel GOTS  
consultable sur  
<http://www.ecocert.com> »



Organic  
Certified by Ecocert Greenlife  
Licence N° 123840

Organic. Certificate  
delivered by Ecocert  
Greenlife according to  
the GOTS Standard  
available on  
<http://www.ecocert.com>.





“ La simplicité est la sophistication suprême. ”  
 “ Simplicity is the ultimate sophistication. ”

Leonard de Vinci

## Linge de table Tablelinen

**Alexandre Turpault** fait sa révolution dans l'art de vivre à Table et cultive cette nouvelle convivialité du 21<sup>ème</sup> siècle beaucoup plus rapide, spontanée et immédiate, très multiforme et nomade, qui a fait exploser les cadres, les codes et les rituels anciens.

Cela ne veut pas forcément dire que l'on passe moins de temps à « table » car nous multiplions ces occasions de petits instants informels de partage et de convivialité.

L'usage du linge au quotidien évolue avec le set de table facile à manipuler et à entretenir, mais la nappe cependant résiste et se réinvente dans des formats plus contemporains.

**Alexandre Turpault** propose des produits sincères et durables, dans une palette variée de matières, de couleurs et de motifs à associer ou à détourner en toute liberté. L'heure est donc aux mélanges, mais toujours dans le respect de la qualité et d'une esthétique chic, simple et efficace chère à la marque.

Pur lin uni longues fibres, tissé, teint et brodé en France. Le traitement stain release Teflon sur la majorité des produits, favorise l'élimination des tâches au lavage tout en préservant le toucher textile.

Un logo créé pour l'occasion et dédié à la nouvelle convivialité est apposé sur tous les produits des nouvelles lignes. C'est un cri de ralliement tellement français mais si fédérateur qu'il transcende les langues et les cultures :

RENDEZ VOUS A TABLE !

**Alexandre Turpault** brings a revolutionary vision into the traditional Art de Vivre at the Table, while cultivating a 21st century new Conviviality that matches our quick paced evolving Lifestyle.

A new , rapid, immediate and more spontaneous, nomadic, multiform way to eat and share meals together has crushed traditional dining codes and rituals including the way we dress table and use linens.

But it does not mean that we spend less time eating, as a matter of fact, moments of informal food sharing and modern conviviality are multiplied. Categories of table linens evolve as well conditioned by quick maintenance and easy usage.

**Alexandre Turpault** offers sincere and durable products in a varied palette of material and colours and patterns to be mix and matched together. The trend is really towards mixity but always in harmony with Alexandre Turpault chic and simple style.

Plain long fibre pure linen, weaved, dyed and embroidered in France, with a stain release treatment for the majority of our products.

A logo celebrates the launching of the New Conviviality table collection and is used on all new lines. It has been conceived as a Rally cry, both so French and so evidently global that it is not necessary to translate :  
 RENDEZ VOUS A TABLE!

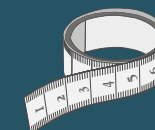

Service sur mesure : dimensions spéciales sur tarif ou sur simple demande.

Custom size service : quotation available on price list or upon request.

### LIN / LINEN

<b>Florence</b> <sup>NEW</sup>	76
Barbade	80
Domaniale	81
<b>Chambray</b> <sup>NEW</sup>	<b>82</b>
<b>Infusion</b> <sup>NEW</sup>	<b>84</b>
Océanide	86



# Florence



blanc / white



Uni lin, jour échelle  
Plain dye pure linen, hemstitch



cuivre / copper

# Florence



rouge rooibos/ rooibos red



Uni lin, jour échelle  
Plain dye pure linen, hemstitch



épeautre / spelt

Made in France

Lin tissé et teint en **FRANCE**  
Linen woven and dyed in **FRANCE**

## COULEURS / COLOURS

blanc white	argent silver	crème cream
rooibos rooibos red	épeautre spelt	cuivre copper
sésame sesame	mimosa mimosa	platane plane tree
naturel natural	Olive	égée aegean blue
fusain ink	noir black	



### NAPPES

Parements de 5 cm,  
coins capuchons, jour échelle.  
170x170 cm  
170x250 cm  
170x320 cm

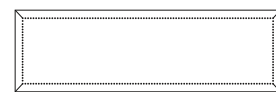

### TABLERUNNER

20x59", 1,5" border  
mitred corners, hemstitch.

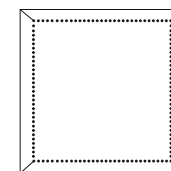

### SERVIETTE

45x45cm, 50x50cm  
coins capuchons, jour échelle

### NAPKIN

18x18" 20x20", 0,8" border,  
mitred corners, hemstitch.

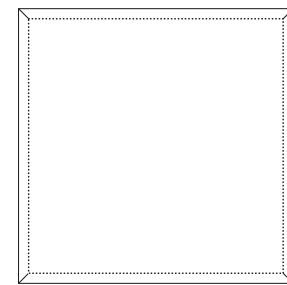

### TABLECLOTHS

2" border,  
mitred corners, hemstitch.  
67x67"  
67x98"  
67x126"

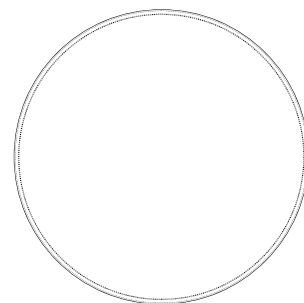

### NAPPE RONDE

Ourlet 1cm, jour échelle.  
D. 180cm

### ROUND TABLECLOTH

0.4" hem, hemstitch.  
D.71"

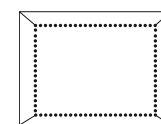

### SET

37x50cm, parements de 4 cm,  
coins capuchons, jour échelle.

### PLACEMAT

15x20", 1,5" border,  
mitred corners, hemstitch.





platane, noir et cuivre  
plane green, black and copper



bleu égée  
aegean blue



platane  
plane green



mimosa  
mimosa yellow



# Barbade

Uni en lin, broderie "Palmiers"  
Plain dye linen, "Palm trees" embroidery



Made in France



COULEURS / COLOURS



AFNOR cert 83773



naturel  
natural

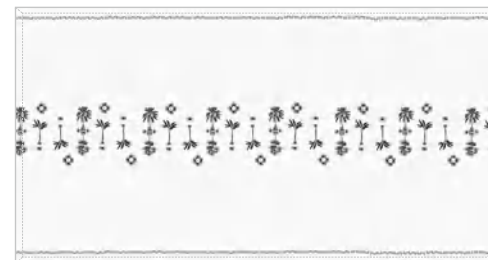

Lin tissé et brodé en FRANCE  
Linen woven and embroidered  
in FRANCE

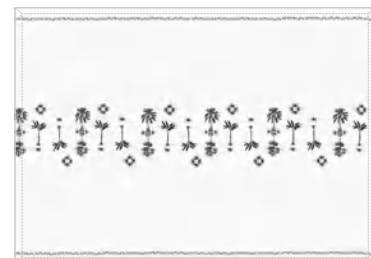

## NAPPE

Lin brodé "Palmiers"  
ourlets 3 cm + coins capuchons  
170x170cm  
170x250cm  
170x320cm

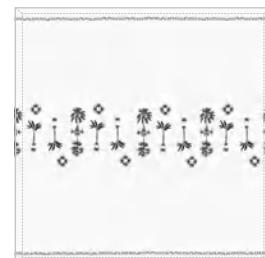

## TABLECLOTH

"Palm trees" embroidered linen  
1,18" mitred corners  
67x67"  
67x98"  
67x126"

# Domaniale

Lin imprimé et brodé "un sentier en forêt"  
Printed sateen "the forest trail"



Made in France



COULEURS / COLOURS



blanc  
white

Lin tissé et brodé en FRANCE  
Linen woven and embroidered  
in FRANCE

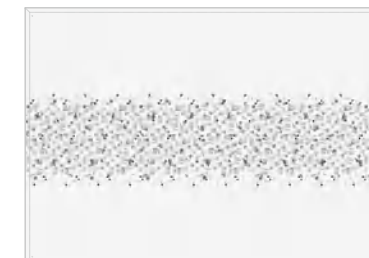
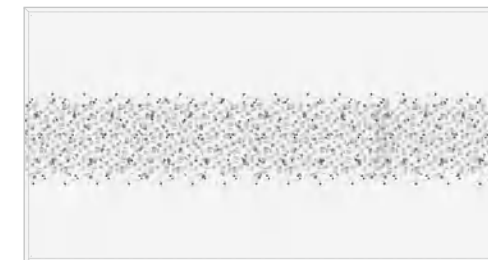

## NAPPE

Lin imprimé et brodé  
"Un sentier en forêt"  
Ourlet 3cm, coins capuchons.  
170x170 cm  
170x250 cm  
170x320 cm

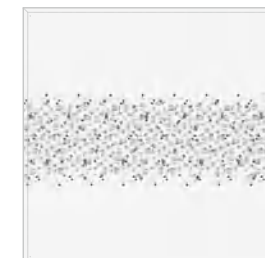

## TABLECLOTH

"the forest trail"  
printed and embroidered linen,  
1,2" hem, mitred corner.  
67x67"  
67x98"  
67x126"



# Chambray

Lin tissé teint, chaîne naturelle et trame couleur  
Yarn dyed pure line with natural warp and coloured weft

NEW



Sauge  
Sage green



Made in France

AFNOR cert 83773

## COULEURS / COLOURS



Lila  
Lilac



Sauge  
Sage green



Yuzu  
Yuzu yellow



Capucine  
Capucine red



### NAPPE

Lin tissé teint, ourlet 3cm, coins capuchons.  
190x190 cm  
190x250 cm  
190x320 cm



### TABLECLOTH

Yarn dyed linen, 1.2" hem, mitred corners.  
74x74"  
74x98"  
74x126"



### SERVIETTE

Lin tissé teint, ourlet 1cm, coins carrés,  
45x45cm

### NAPKIN

Yarn dyed linen, 0.4" hem, square corner.  
18x18"



Capucine  
Capucine red



Lila  
Lilac



Yuzu  
Yuzu yellow



Sauge  
Sage green & Yuzu  
Yuzu yellow



# Infusion

Lin uni brodé "Graminées". Capsule édition limitée upcyclée.  
Plain dye embroidered linen "Grasses". Upcycled, limited edition

NEW



Spéculoos  
Spéculoos brown

Made in France

## COULEURS / COLOURS



Lin tissé et brodé en **FRANCE**  
Linen woven and embroidered  
in **FRANCE**



Basilic  
Basil green



Spéculoos  
Spéculoos brown

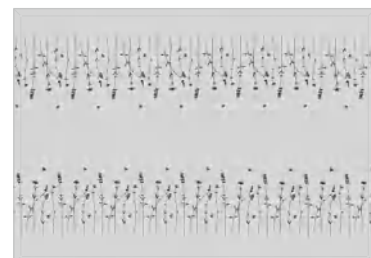
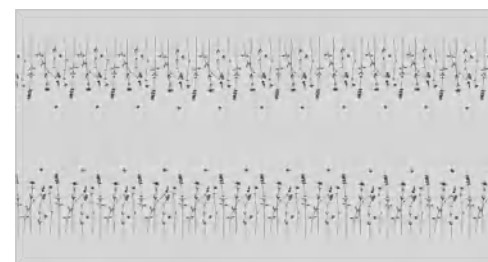

### NAPPE

Lin uni brodé "Graminées", Ourlet  
3cm, coins capuchons.  
170x170cm  
170x250cm  
170x320cm

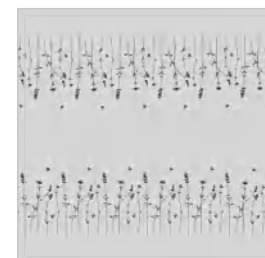

### TABLECLOTH

Embroidered plain dye linen  
"Grasses", 1.2" hem, mitred corners.  
67x67"  
67x98"  
67x126"



Basilic  
Basil green



# Océanide

Lin imprimé et brodé "Comment naissent les étoiles"  
Embroidered printed linen "how stars are born"



Made in France

COULEURS / COLOURS

ORIGINE  
**FRANCE**<sup>®</sup>  
GARANTIE

AFNOR cert 83773

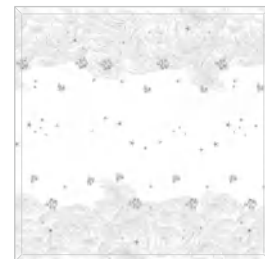
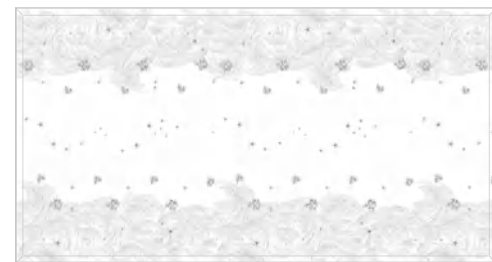

## NAPPES

Lin imprimé et brodé  
"Comment naissent les étoiles",  
Ourlet 3cm, coins capuchons.  
170x170 cm  
170x250 cm  
170x320 cm

## TABLECLOTHS

Embroidered and printed linen  
"How stars are born",  
1.2" hem, mitred corners.  
67x67"  
67x98"  
67x126"







## La question des emballages

Dans le cadre de la **politique RSE**<sup>1</sup> du groupe Vanderschooten engagé dans une action globale sur la réduction de son empreinte carbone et forte de ses valeurs fondatrices depuis 1847, la société Alexandre Turpault concentre son action sur la promotion des fabrications locales et des certifications Origine France Garantie, l'utilisation de matières naturelles cultivée dans le cadre d'une agriculture biologique ou raisonnée certifiée par des labels de qualité comme GOTS, la limitation et recyclage des chutes textiles, la suppression des matières plastiques.

La problématique des emballages de protection impacte plusieurs phases opérationnelles depuis le stockage, transport, merchandising, jusqu'à la vente finale. L'interdiction des plastiques à usage unique en Europe, le souhait de restreindre la production de matières inutilement polluantes pour la planète nous conduit à remettre en cause l'utilité réelle des emballages.

La démarche est plus éthique qu'économique car produire propre coûte beaucoup plus cher.

Engagée pour PE21, la conversion des emballages pour les produits en collection sera totalement achevée d'ici la fin d'année 2021 pour la collection PE22.

Désormais la totalité des collections Alexandre Turpault sera emballée de façon écologique :

- Abandon des matières plastiques<sup>2</sup>
- Pochons et liens textiles réutilisables.
- Papiers et cartons recyclables imprimés avec encres végétales.
- Suppression des suremballages et promotion d'un vrac bien plié.

Les éléments d'emballages restant sont fabriqués le plus localement possible en France et dans des matières recyclées ou recyclables. Les pochons textiles sont fabriqués dans les ateliers au moment de la fabrication de chaque article afin de ne pas générer de surplus inutiles.

## The question of packaging

Within the framework of the **CSR**<sup>1</sup> policy of the Vanderschooten group, engaged in a global action on the reduction of its carbon footprint and on the strength of its founding values since 1847, the company Alexandre Turpault is focusing its action on the promotion of local manufacturing and Origine France Garantie certifications, the use of natural materials cultivated by organic or reasoned agriculture certified by quality labels such as GOTS, the limitation and recycling of textile scraps, the elimination of plastics.

The issue of packaging impacts several operational phases from storage, transport, merchandising, to final sale. The ban on single-use plastics in Europe and the desire to restrict the production of materials that pollute the planet needlessly lead us to question the real usefulness of packaging.

The approach is more ethical than economic because producing clean is much more expensive.

Started for SS21, the conversion of packaging for products in collection will be fully completed by the end of 2021 for SS22.

From now on, all of the Alexandre Turpault collections will be packaged in an ecological way:

- Zero plastics<sup>2</sup>
- Reusable textile bags and ties.
- Recyclable paper and cardboard printed with vegetable inks.
- Elimination of overwrapping and promotion of well-folded bulk.

The remaining packaging elements are made as locally as possible in France and from recycled or recyclable materials. The textile pouches are manufactured in the workshops at the time of manufacture of each item so as not to generate unnecessary surplus.

<sup>1</sup> Responsabilité Sociale (économique et environnementale) de l'Entreprise

<sup>2</sup> Exception pour les produits en fin de série déjà emballés.

<sup>1</sup> CSR: Corporate Social (economical and environmental) Responsibility

<sup>2</sup> Exception for discontinued items that already packaged.



# Les nouveaux emballages en détail

## LE LIT

- Taies avec encart dos et 2 cartelettes devant, le tout ficelé par un lien textile<sup>1</sup>.
- Draps plats et housses de couette en pochon textile pris dans le tissu principal de chaque modèle, à fermeture coulissante avec 3 cartelettes sur le devant (dont 1 avec photo produit)
- Draps housse enserrés dans un fourreau carton, le tissu est visible sur les côtés. Sauf pour Nouvelle Vague qui garde son emballage original.

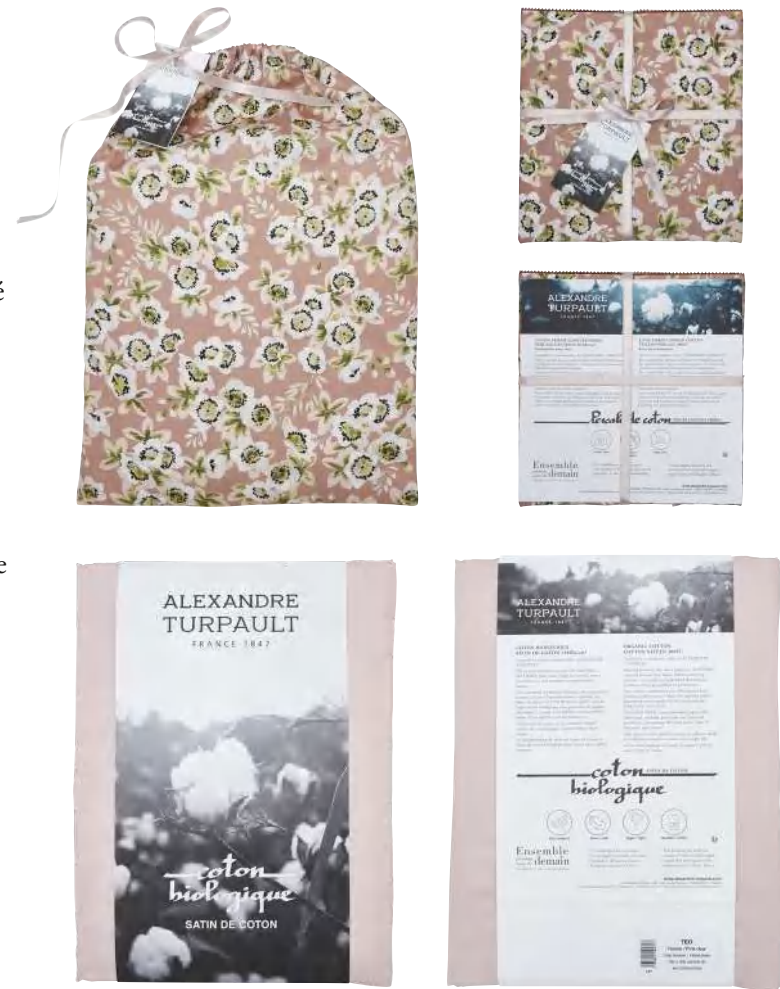

<sup>1</sup> Pour les modèles en satin de coton non bio encore en collection, pas d'encart pour les taies, mais 3 cartelettes.

## LES ACCESSOIRES

Pochon textile pour les couvre lits, courte pointes, plaid fourrures. Pliés avec cartelettes pour les housses de coussin et les plaids léger.



## LE BAIN

Plié avec cartulette sans suremballage plastique à épuisement de nos stocks.

## LA TABLE

Les nappes et tête à tête restent en boîte, mais les sets et serviettes sont pliés et livrés sans suremballage plastique à épuisement de nos stocks.

En conclusion, l'emballage le plus écologique, à vrai dire c'est sans doute plus d'emballage du tout...

# New packaging in detail

## BED

- Pillowcases with insert on the back and 2 labels in front, all tied with a textile tie<sup>1</sup>.
- Flat sheets and duvet cover in textile pouch taken from the main fabric of each model, with sliding closure with ribbon and 3 leaflets at the front (including 1 with product picture)
- Fitted sheet enclosed in a cardboard sleeve, the fabric is visible on both sides. Except for Nouvelle Vague which keeps its original packaging.



<sup>1</sup> For the non organic cotton sateen designs still in collection, there is no cardboard for the pillowcase but 3 leaflets.

## ACCESSORIES

Textile pouch for bedspreads, small bed cover, fur cover. Folded with ribbon and leaflets for cushion covers and lightweight throws.



## BATH

Folded with leaflet without plastic overwrapping once our stocks are finished.

## TABLE

Tablecloths and runners remain in the box, but folded sets and napkins are delivered without plastic overwrapping once our stock is finished.

By the way, the most ecological packaging is probably no more packaging at all...





Envolée <sup>NEW</sup>  
17



Baroque <sup>NEW</sup>  
28

**Lit satin de coton bio \ organic cotton sateen bedlinens**



Teophile 6



Marceau 10



Orsay 12



À la belle étoile <sup>NEW</sup> 14



Blossom 15



Chandernagor 16



Envolée <sup>NEW</sup> 17



Halatte 18



Octobre 19

**Lit satin / Cotton sateen bedlinen**

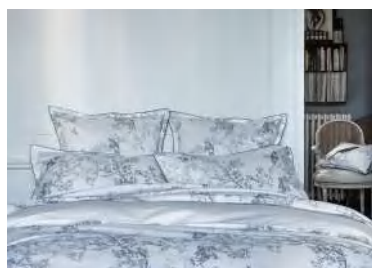

Canopée 22

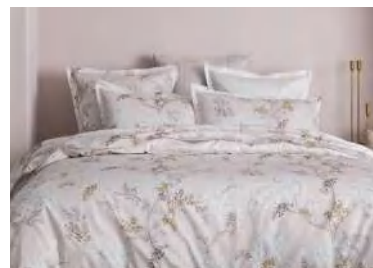

Quintessence 23



Namaste 24-25

**Lit percale de coton / Cotton percale bedlinen**



Baroque <sup>NEW</sup> 28



Candide 29



Sous-bois 30



Trésor 31

**Lit lin / Pure linen bedlinen**



Cythère 34



Maine 35



Nouvelle Vague <sup>NEW</sup> 36-39



Bastide 40

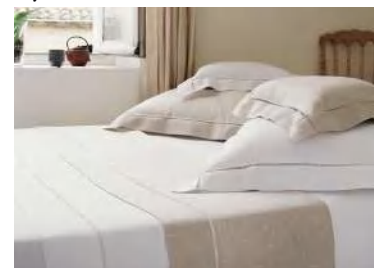

Keops 41



Régence 42

**Lit metis / Halfinen bedlinen**



Cachou 46



Ontario 46



Paris 47



Venise 48





Accessoires / Accessories



Bel Oiseau 52



Bloom 53



Estampe 54



L'île aux oiseaux NEW 55



Loulou 56



Nomade 57



Merveille 58



Poesie NEW 60



Tsarine 62



Ashlyn 63 Velin 63



Voltaire 64

Linge de toilette \ Bathlinen



Essentiel 68



Ess-cadre 69



Ess-cale | Ess-kimo 70

Plage / Beach Towels



Belize NEW 72



Succulente NEW 73



Table lin / linen

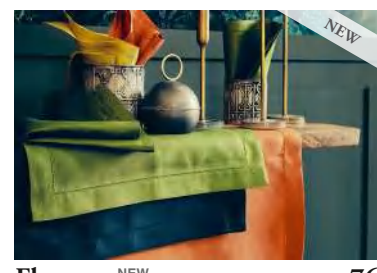

Florence NEW 76



Barbade 80



Domaniale 81



Chambray NEW 82



Infusion NEW 84

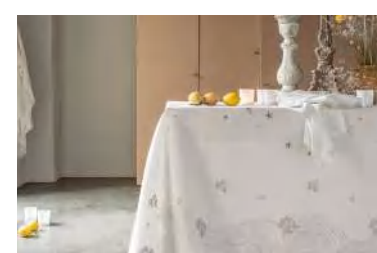

Océanide 86



# Conseils d'entretien de votre linge





Notre linge raffiné pour la maison est réalisé dans des matières naturelles de qualité, selon la tradition française, il gardera sa qualité au fil des ans à condition d'être soigneusement entretenu.

Tous nos produits sont livrés avec les instructions de nettoyage et portent une étiquette avec les symboles universels de lavage.

## L'ENTRETIEN DU LINGE :

- \* Plus vous lavez le linge Alexandre Turpault plus il sera beau, souple, lumineux et doux.
- \* Retournez sur l'envers les taies et les couettes, ainsi les rubans et les broderies seront protégés.
- \* Nous vous recommandons d'utiliser des lessives sans azurant optique. Ils sont irritants et polluants et n'ont aucun pouvoir lavant.
- \* Veillez à laver toutes les pièces d'une parure ensemble, sans les mélanger avec d'autres matières ou coloris
- \* L'essorage de votre linge de maison en lin doit être modéré et le séchage doit être suspendu pour faciliter le repassage.
- \* Le lin doit être repassé encore humide pour un meilleur résultat. Les broderies doivent être repassées à l'envers et sous pattemouille.

LIN :     

COTON ET METIS :     

L'ENTRETIEN DE L'EPONGE :     

# Care instructions

Our linens of bed, bath and table are made with the finest natural fibers, in the classic French tradition, they will last for many years, with a proper care.

All of our linens are packaged with care instructions, and all have sewn-in labels with universal laundering symbols

## CARE OF LINEN :

- \* Your Alexandre Turpault linen will become more beautiful, soft, bright and gentle the more you wash it.
- \* Wash pillowcases and duvet covers inside out to protect ribbons and embroideries.
- \* We recommend the use of detergents which do not contain optical brighteners. They are irritant and polluting and have no cleaning power.
- \* Wash your linens set together, separately from anything else
- \* Use a gentle spin cycle for your household linen and hang to dry to make ironing easier.
- \* Linen fabric is be ironed while still wet for a better result. All embroideries have to be ironed inside-out over a wet fabric in order to protect the yarn.

LINEN :    

COTTON AND HALFLINEN :     

CARE OF TOWELING :    



ALEXANDRE  
TURPAULT  
FRANCE 1847





Conception graphique  
© www.olivierclasse.fr  
www.aodimpression  
impression

M Photos @www.in-agence.fr



ALEXANDRE  
TURPAULT  
PARIS - FRANCE

2022

**Alexandre Turpault SAS** - 660, rue de l'Épinette - 59850 NIEPPE (France)  
Téléphone : +33 (0)3 20 44 14 41 - Fax : +33 (0) 3 20 44 14 21  
International sales phone : +33 (0)320 440 722 - Fax : +33 (0)320 440 725  
E-mail : [contact@alexandre-turpault.com](mailto:contact@alexandre-turpault.com)  
Site : [www.alexandre-turpault.com](http://www.alexandre-turpault.com)



Follow us on :

Photos non contractuelles  
Copyright mars 2022